

GOLDEN WHEEL

No. 004014

CS-411N

1-NEEDLE, LOCKSTITCH SUPER LONG CYLINDER
BED, BOTTOM FEED, SEWING MACHINE FOR
HEAVY DUTY MATERIALS.

Please read this Instruction Manual carefully
before using the unit in order to get the most
out of it and to enjoy using it for a long time.
Please keep this Instruction Manual at hand
taking care not to lose it.

INSTRUCTION MANUAL

BEFORE OPERATION

1. Do not operate the machine even for trial before lubrication it.
2. Confirm that the voltage and phase (single or 3-phase) are correct by checking them against the ratings shown on the motor nameplate.
3. When running your machine for the first time after the set-up, check the rotational direction of the handwheel. ★ Turn on the power switch. Run the machine at a low speed while checking the rotational direction of the handwheel. (The handwheel should turn counterclockwise as observed from the handwheel side.)
4. For the first month, run the machine at speed of 500 s. p. m. or less.

CAUTIONS IN OPERATION

1. Keep your hands away from the needle when you turn on the power switch or while the machine is operating.
2. During operation, be careful not to allow your or any other person's head or fingers to come close to the handwheel, V-belt, bobbin winder or motor. Also, do not place anything close to them.
3. Do not turn the machine with the finger guard, belt cover or any other protectors removed.
4. Be sure to turn off the power switch and confirm that the motor is completely stopped before removing the V-belt.

SPECIFICATIONS

Usage	Golf Bag
Sewing speed	Max 800s. p. m.
Stitch length	Max: 11mm
Needle	Schmetz 794 Nm230 (Nm130~Nm280)
Lift of presser foot	Hand lifter: 12 mm, Knee lifter: 20 mm
Lubricating oil	Machine oil (white spindle oil)

1. INSTALLING THE THREAD STAND

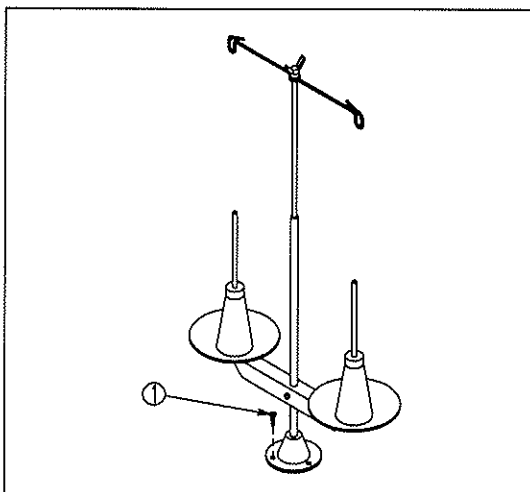

Assemble the Thread stand, and install it to the righthand side of the far side of the table with screws ① (at 3 places).

2. INSTALLING THE BELT COVER



CAUTION

TURN THE SWITCH OFF THE POWER SUPPLY TO PREVENT FROM UNEXPECTED INJURY. BE SURE TO CONFIRM THE STOP OF ROTATION OF THE MOTOR BEFORE OPERATIONS.

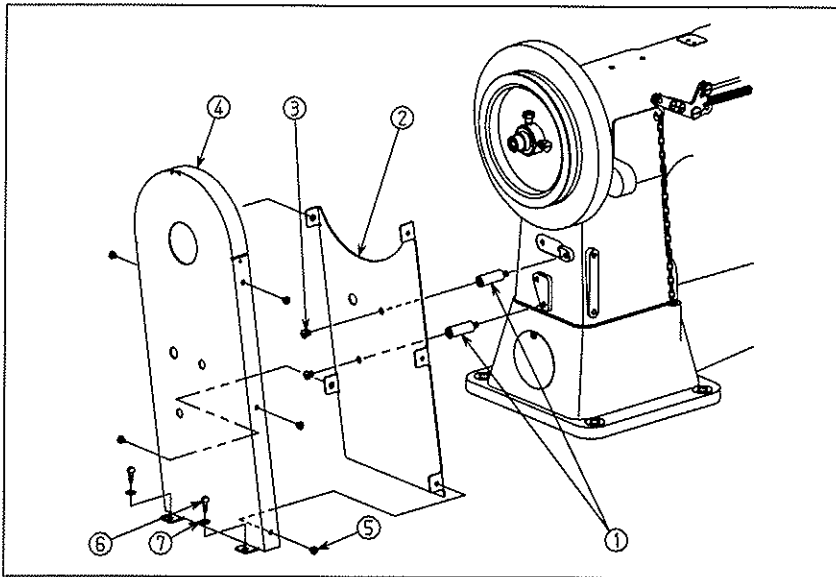

- 1) Install two belt cover supports ① to the machine arm
- 2) Install belt cover B ② to belt cover supports ① using screws ③.
- 3) Attach belt cover A ④ to belt cover B ② using screws ⑤.
- 4) Fix belt cover A ④ on the table using wooden screw ⑥ and washer ⑦.

3. CLEANING

Waste thread, dust, dirt, etc., build-up around the presser foot or the shuttle may cause malfunction of the machine.

Clean periodically according to your frequency of use.

- 1) Clean around the presser foot after removing the throat plate.
- 2) Clean the inside of the shuttle race body by taking out the shuttle body after removing the cover of the shuttle race body.

4. LUBRICATION

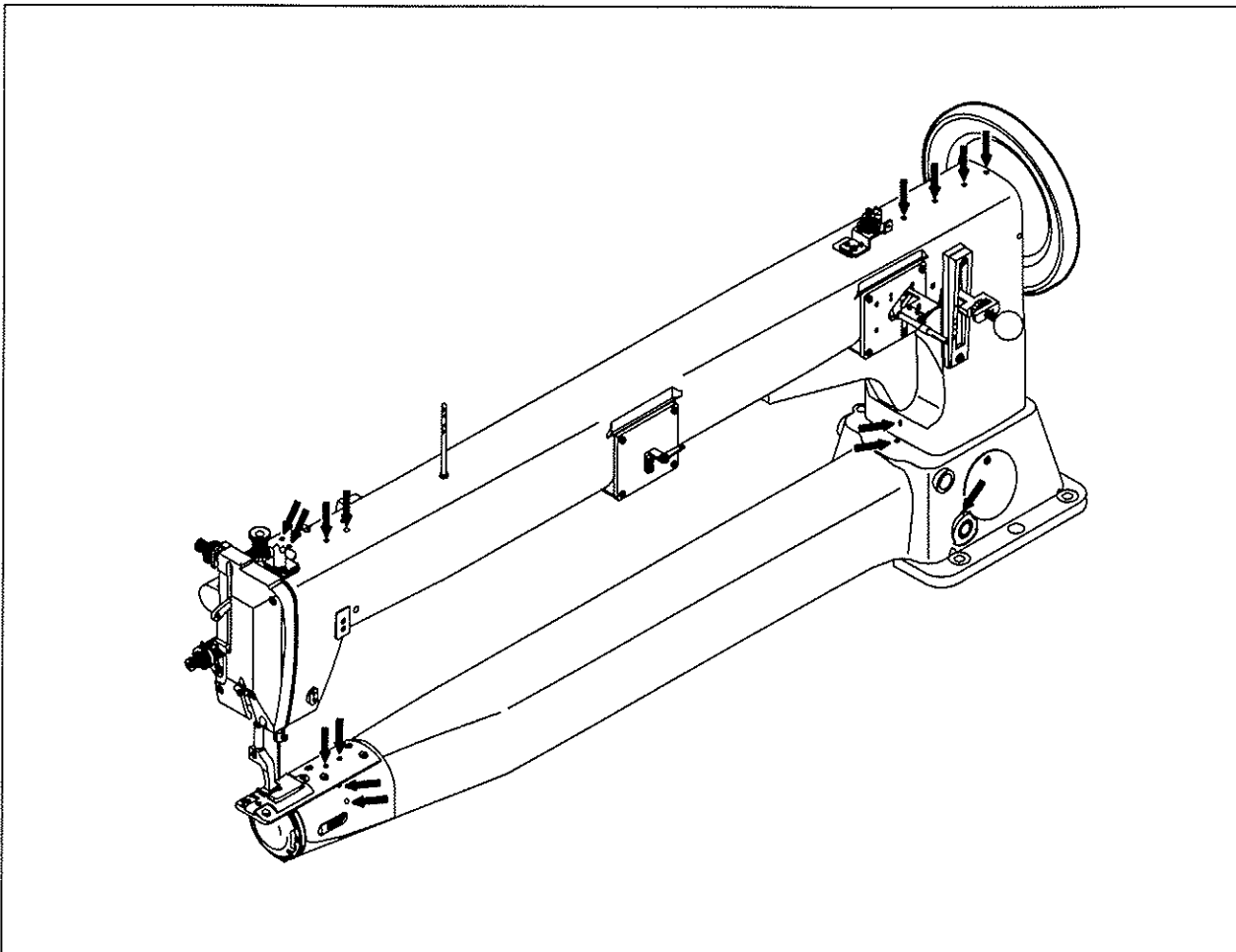

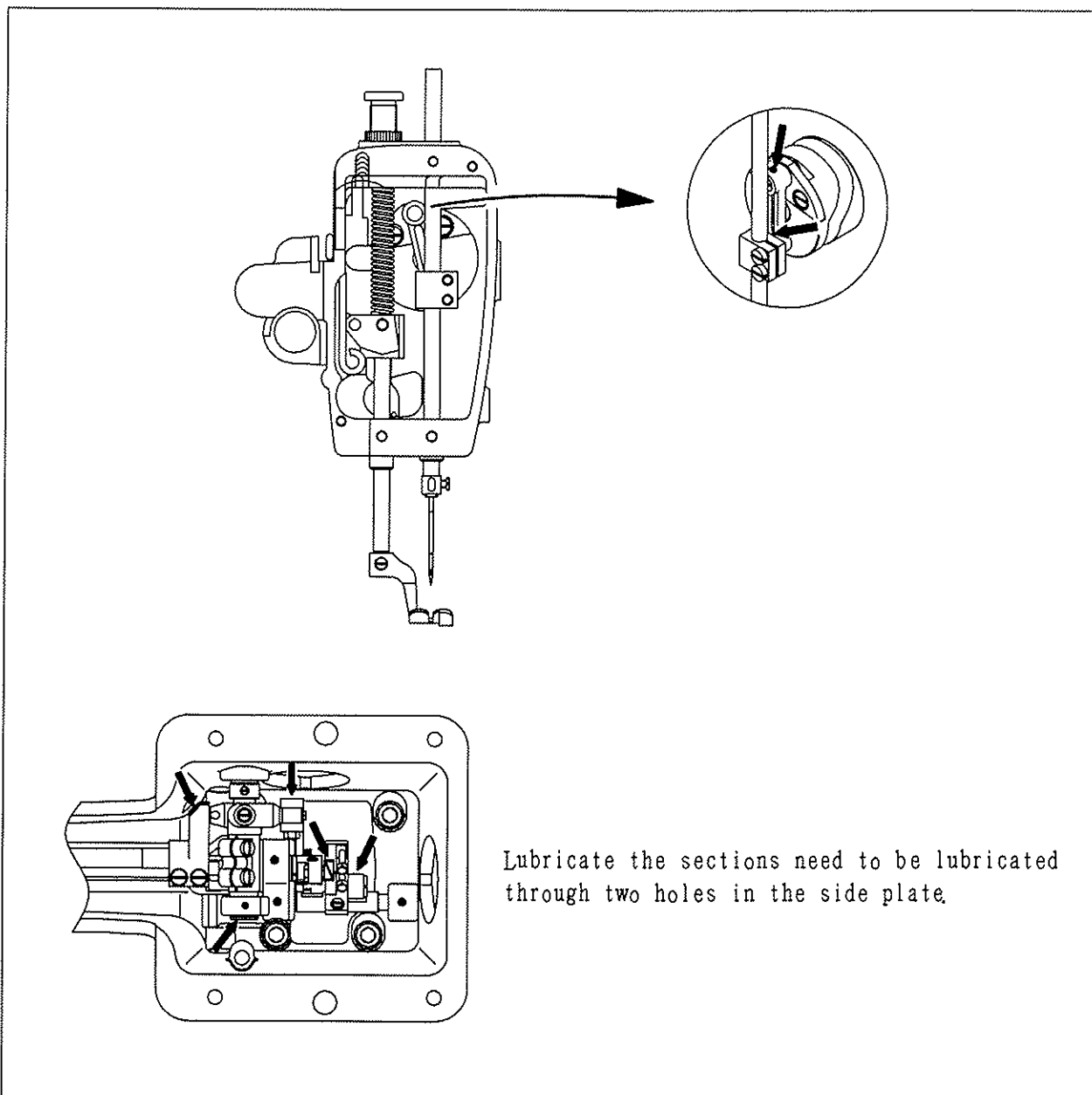

- 1) After uncrating, supply oil to the machine after cleaning it thoroughly.
- 2) When oiling all the sections requiring lubrication, after installation of the machine has been completed, wait for a while (approximately 10 minutes) so that oil can penetrate each section sufficiently before starting continuous operation.
- 3) To operating the machine continuously, apply two to three drops of oil to each section noted with an arrow mark in the following figure whenever starting operation in the morning and in the afternoon.

5. HOW TO INSTALL THE NEEDLE



CAUTION

TURN THE SWITCH OFF THE POWER SUPPLY TO PREVENT FROM UNEXPECTED INJURY. BE SURE TO CONFIRM THE STOP OF ROTATION OF THE MOTOR BEFORE OPERATIONS.

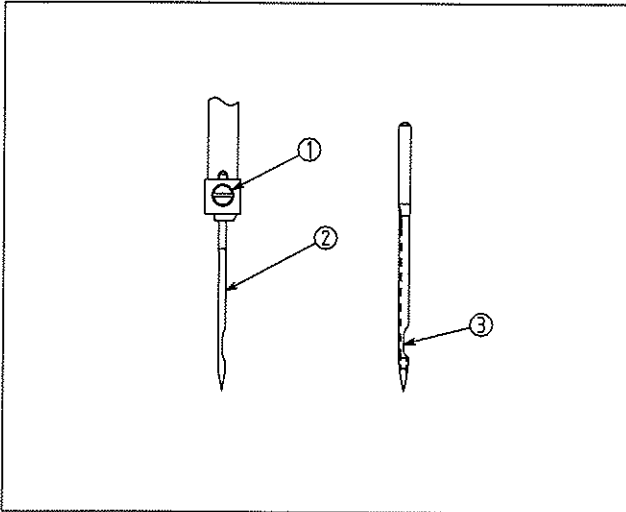

◆BE SURE TO POWER-OFF THE MOTOR

The normal needle system is a Schmetz 794, however an Organ DYX3 can be used.

- 1) Turn the handwheel by hand and raise the needle bar to its top position.
- 2) Loosen screw ① and insert the needle ② into the hole until it will go no further.
◆ Insert the needle with its recess ③ facing directly to the right-hand side.
- 3) Securely tighten the screw in the needle.

6. HOW TO TAKE OUT THE BOBBIN



CAUTION

TURN THE SWITCH OFF THE POWER SUPPLY TO PREVENT FROM UNEXPECTED INJURY. BE SURE TO CONFIRM THE STOP OF ROTATION OF THE MOTOR BEFORE OPERATIONS.

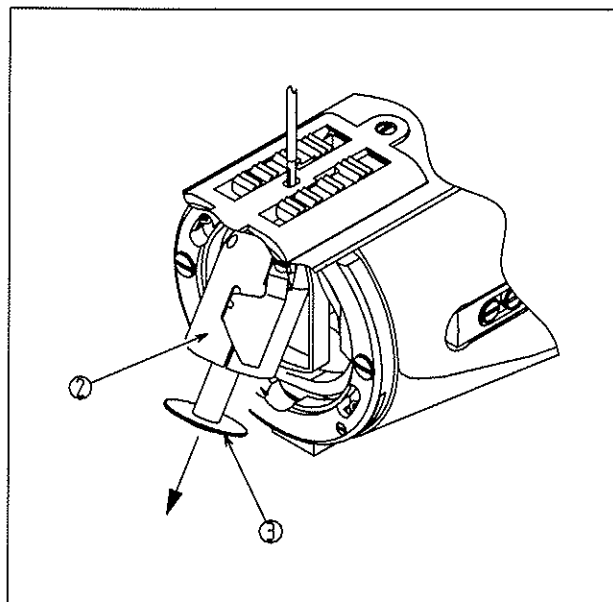
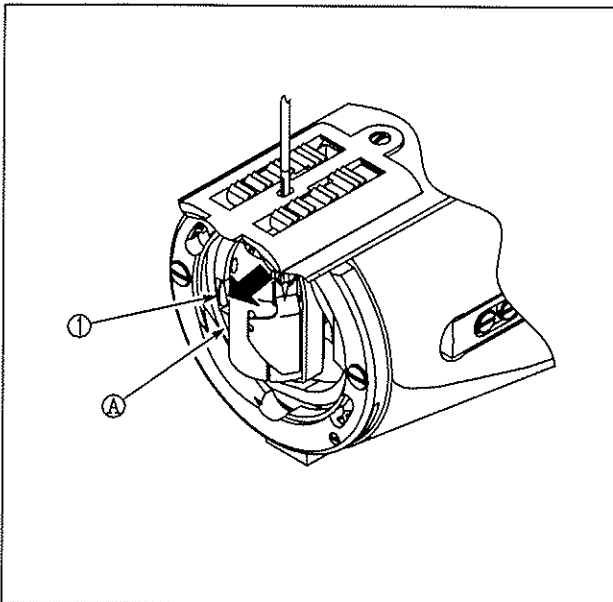

- 1) Turn the handwheel by hand (until the needle bar comes down to the lowest point of its stroke) so that case retaining spring ① in the shuttle body come to recess A in the cover of the shuttle race body.
- 2) When the case retaining spring is pressed, the bobbin case ② will be opened and the bobbin ③ will pop out of the case.

7. HOW TO WIND A BOBBIN THREAD



CAUTION

TURN THE SWITCH OFF THE POWER SUPPLY TO PREVENT FROM UNEXPECTED INJURY. BE SURE TO CONFIRM THE STOP OF ROTATION OF THE MOTOR BEFORE OPERATIONS.

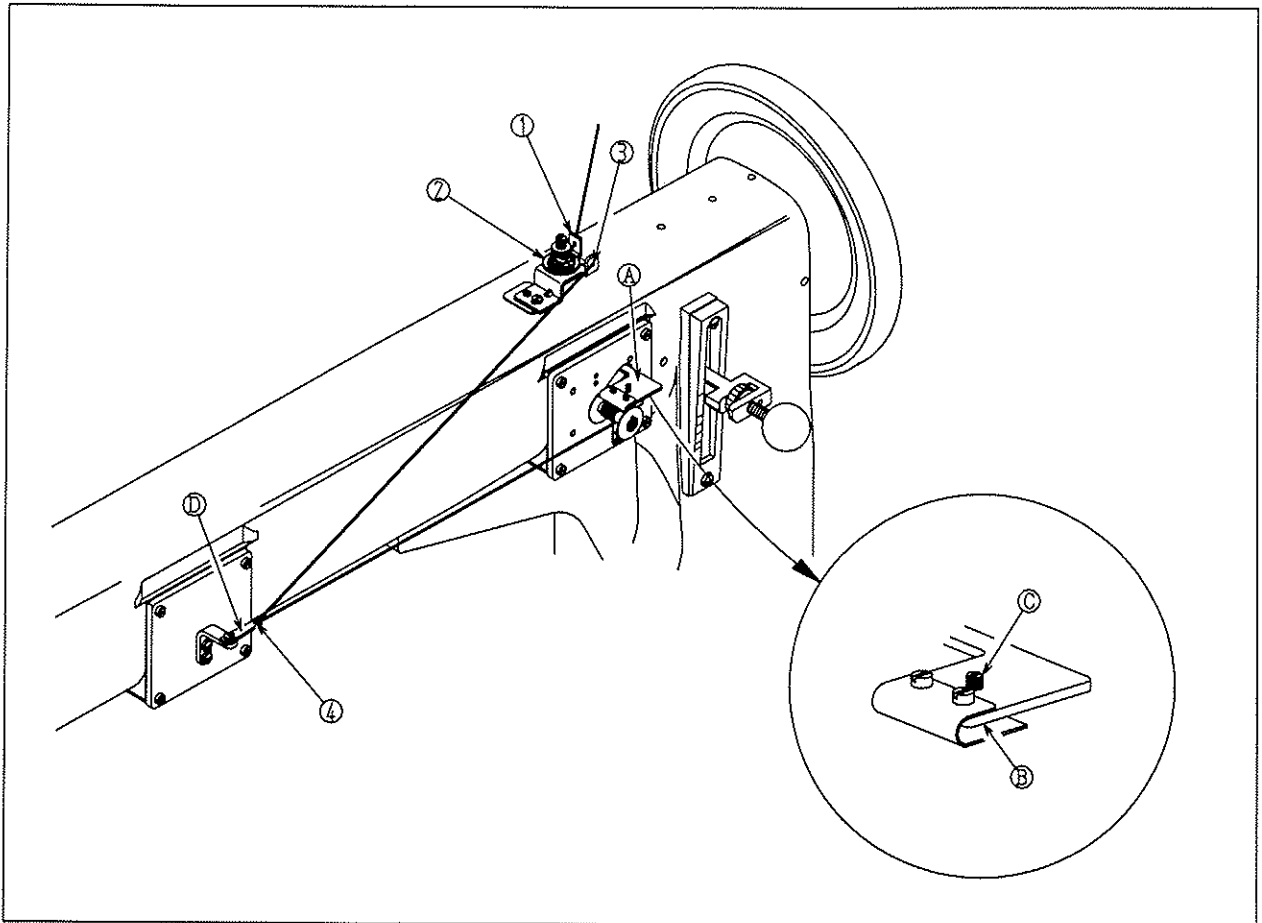

- 1) Raise the presser foot by the hand lifter lever.
- 2) Insert the bobbin into the bobbin winder spindle.
- 3) Thread the winder in the order illustrated and wind the thread onto the bobbin four or five turns.
- 4) Push the bobbin winder trip latch (A) down and the bobbin starts rotating to wind bobbin thread with the machine operated.
- 5) When winding of bobbin thread has been completed, the bobbin winder trip latch (A) will be disengaged and the bobbin will stop automatically.

◆ Adjusting the amount of thread wound round the bobbin

That amount of thread has already been adjusted so that thread can be wound round approximately nine-tenths of the bobbin. If the amount is excessive or insufficient, adjust:

- 1) by loosening the adjusting screw nut (B).
 - 2) by turning the adjusting screw (C). To decrease the amount, turn clockwise. To increase the amount, turn counterclockwise.
 - 3) After adjusting the amount of thread has been completed, tighten the nut to secure firmly.
- ◆ If bobbin thread is wound unevenly, move the bobbin winder thread guide (D) forward and backward so that thread can be wound evenly.

8. HOW TO INSTALL THE BOBBIN



CAUTION

TURN THE SWITCH OFF THE POWER SUPPLY TO PREVENT FROM UNEXPECTED INJURY. BE SURE TO CONFIRM THE STOP OF ROTATION OF THE MOTOR BEFORE OPERATIONS.

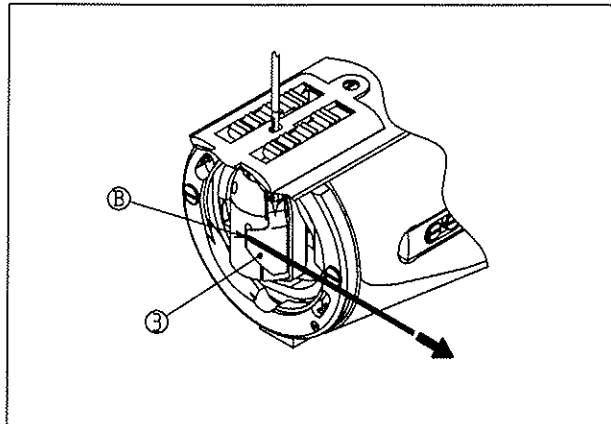
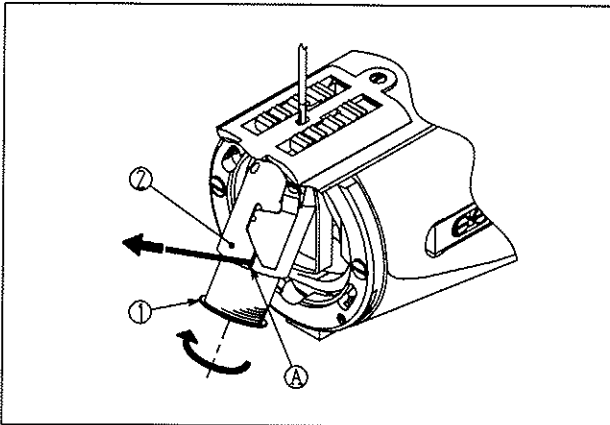

1) After pulling out thread approximately 10 cm from bobbin ①, put the bobbin into bobbin case ②.

2) Pass the thread through the threading groove A in the bobbin case.

Caution) Fit the bobbin in the bobbin case so that the bobbin turns in the direction of the arrow when the bobbin thread is pulled.

3) Pass the thread through thread slit B and pull it up. Then the thread can be passed under the thread tension spring C and pulled out.

4) Push the bobbin case into the original position of holding the bobbin.

9. HOW TO THREAD THE MACHINE HEAD



CAUTION

TURN THE SWITCH OFF THE POWER SUPPLY TO PREVENT FROM UNEXPECTED INJURY. BE SURE TO CONFIRM THE STOP OF ROTATION OF THE MOTOR BEFORE OPERATIONS.

1) Turn the handwheel by hand to move the thread take-up lever to its top position.

2) Thread in the order illustrated and thread the needle from the left to the right.

3) Pull out the thread, which has been threaded in the needle, approximately 10 cm.

Caution) Thread the right-hand side of section B when viewed from the face plate.

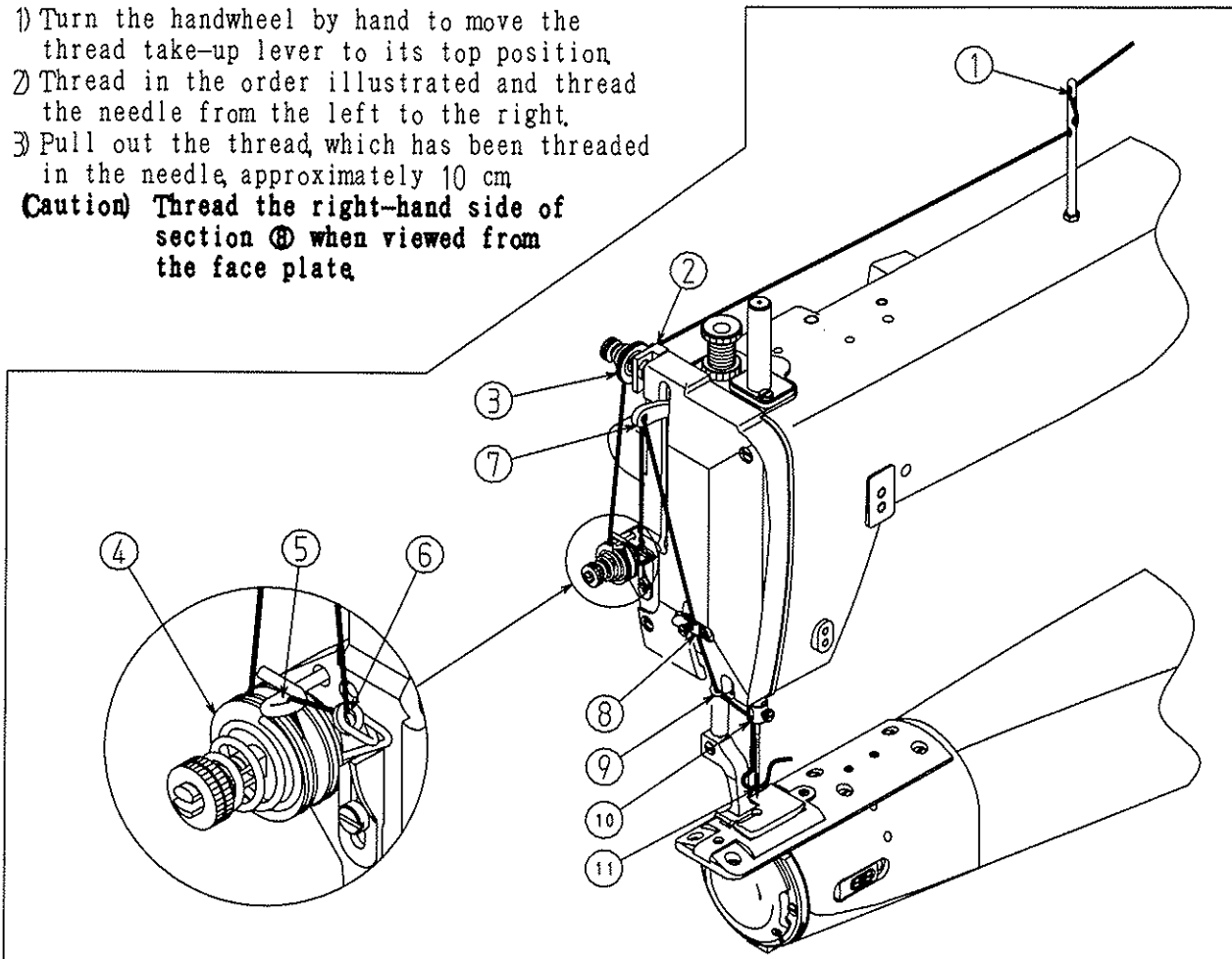

10. ADJUSTING THE STITCH LENGTH AND REVERSE STITCHING

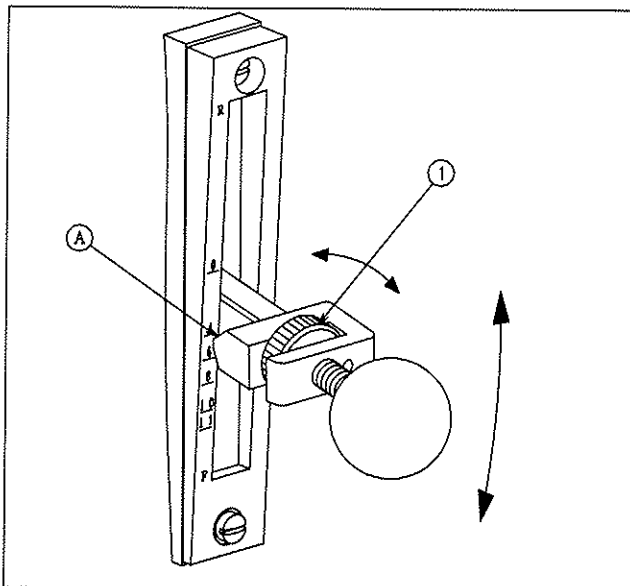

◆Adjusting the stitch length

To adjusting the stitch length, use the feed regulator nut ①.

Align the upper end ① of the feed lever to the scale indicating the desired amount.

To increase the pitch, turn the nut counter-clockwise.

To decrease the pitch, turn the nut clockwise. (To decrease the stitch length, turn the nut while slightly pushing the feed lever down.)

11. THREAD TENSION



CAUTION

TURN THE SWITCH OFF THE POWER SUPPLY TO PREVENT FROM UNE-EXPECTED INJURY. BE SURE TO CONFIRM THE STOP OF ROTATION OF THE MOTOR BEFORE OPERATIONS.

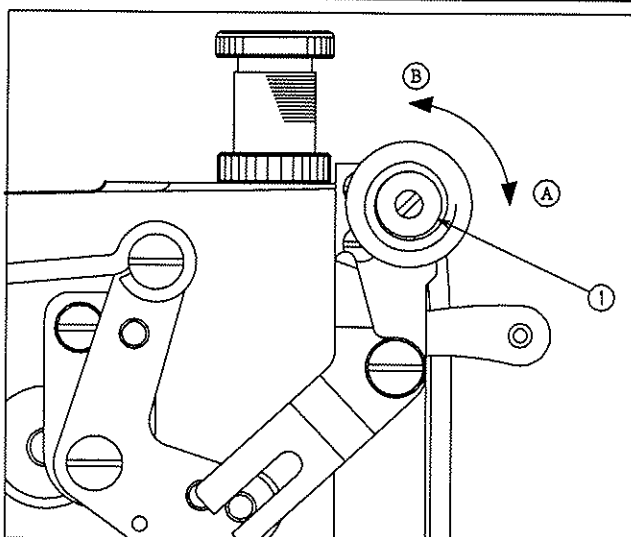

◆Adjusting the needle thread tension

Adjust the needle thread tension by thread tension nut ①.

To increase the needle thread tension, turn the nut to the clockwise ①.

To decrease the needle thread tension, turn the nut to the counterclockwise ②.

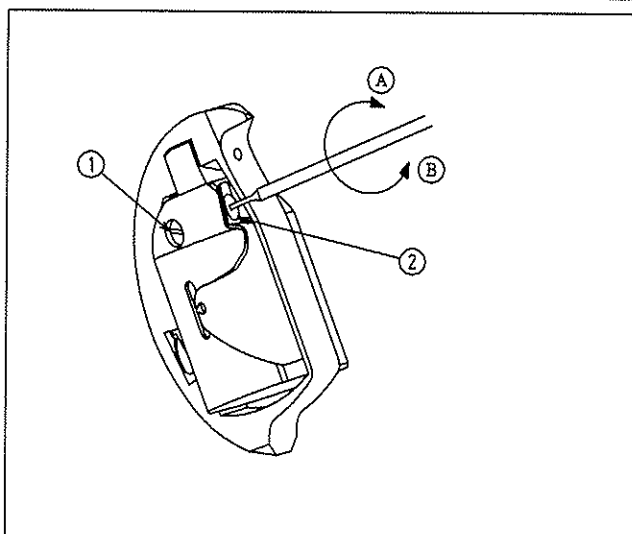

◆Adjusting the bobbin thread tension

To adjusting the bobbin thread tension

- 1) Loosen screw ①.
- 2) Adjust the bobbin thread tension by turning screw ②.

To increase the bobbin thread tension, turn the screw to the clockwise ①.

To decrease the bobbin thread tension, turn the screw to the counterclockwise ②.

- 3) After the bobbin thread tension has been adjusted, tighten screw ① firmly.

12. THE THREAD TAKE-UP SPRING



TURN THE SWITCH OFF THE POWER SUPPLY TO PREVENT FROM UNEXPECTED INJURY. BE SURE TO CONFIRM THE STOP OF ROTATION OF THE MOTOR BEFORE OPERATIONS.

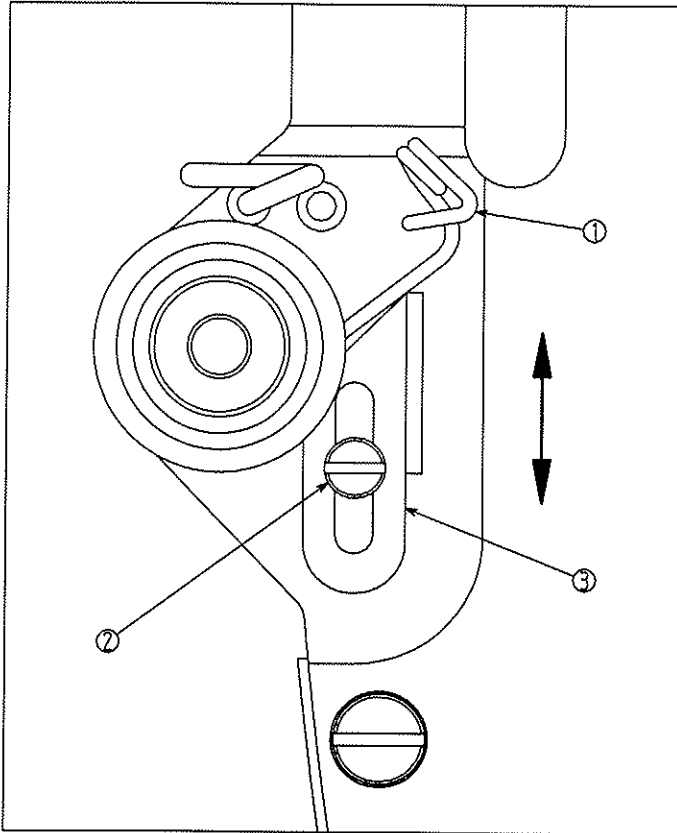

The normal stroke of thread take-up spring ① is 14 to 16 mm

To adjust the operating range:

- 1) Loosen screw ②.
- 2) Adjust the operating range by moving thread the take-up spring adjusting plate ③ up and down.
- 3) After adjustment has been completed, tighten screw ② firmly.

13. ADJUSTING THE PRESSER FOOT PRESSURE



TURN THE SWITCH OFF THE POWER SUPPLY TO PREVENT FROM UNEXPECTED INJURY. BE SURE TO CONFIRM THE STOP OF ROTATION OF THE MOTOR BEFORE OPERATIONS.

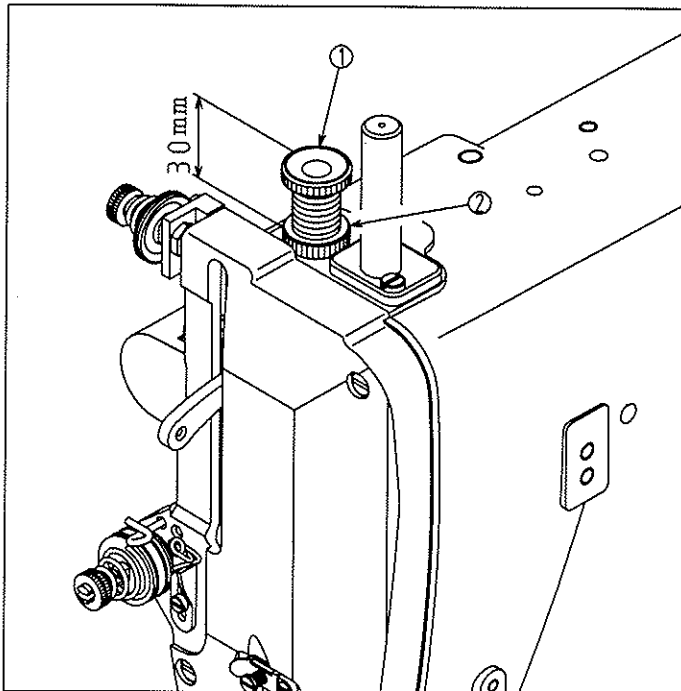

Normal height of presser spring regulator ① is 30 mm

The intermediate presser foot pressure can be adjusted according to the type of material to be used

To adjust the presser foot pressure, follow the procedure stated below

- 1) Loosen the nut of presser spring regulator ②.
- 2) Turn the regulator ① clockwise to increase the pressure, or counterclockwise to decrease it.
- 3) After the adjustment, tighten the nut ② so that regulator is securely fixed at the proper position.

◆ Operate the machine with the presser foot pressure minimized.

14. ADJUSTING THE HEIGHT OF THE FEED DOG



CAUTION

TURN THE SWITCH OFF THE POWER SUPPLY TO PREVENT FROM UNEXPECTED INJURY. BE SURE TO CONFIRM THE STOP OF ROTATION OF THE MOTOR BEFORE OPERATIONS.

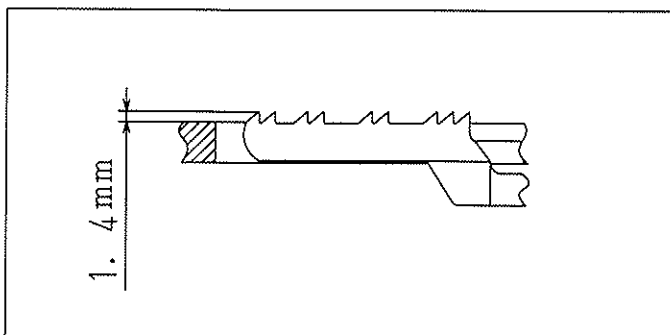

The advance amount of the feed dog from throat plate has already been adjusted to 1.4 mm

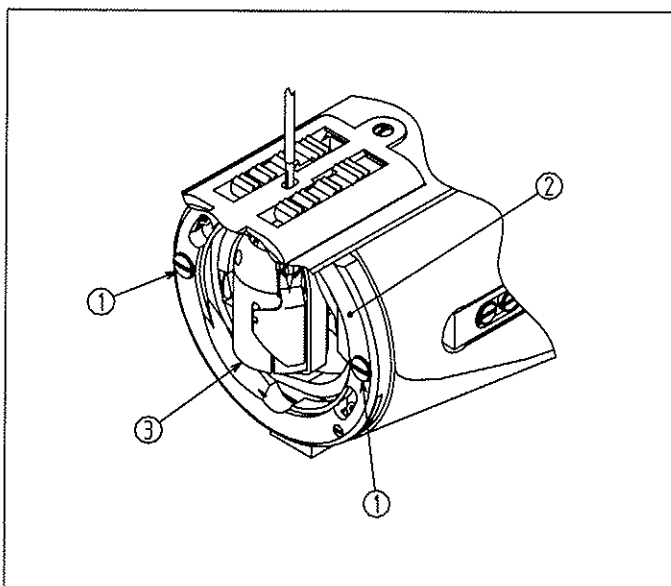

To adjust the height of the feed dog according to the sewing condition given,
 1) Remove two screws ① in the shuttle race, and remove shuttle race ②. Then remove shuttle ③.

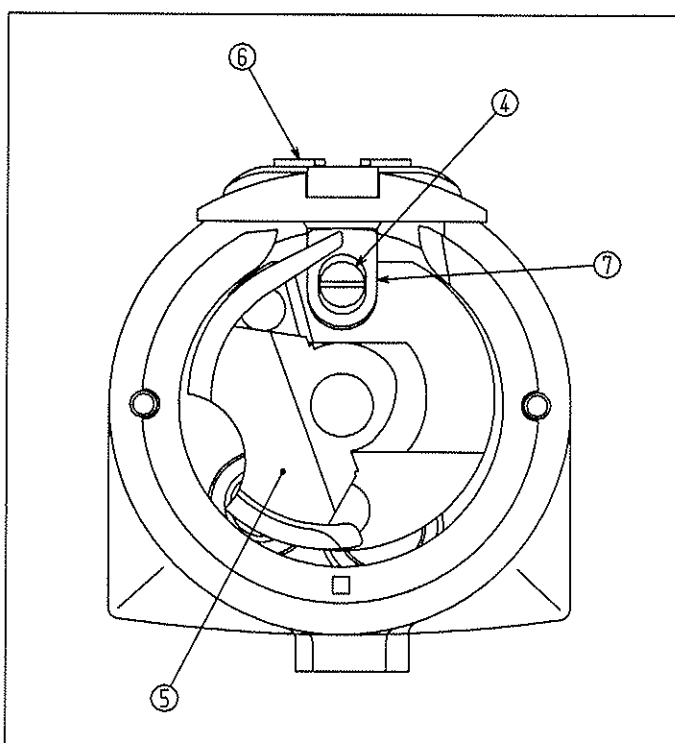

- 2) Turn the handwheel to move shuttle driver ⑤ until screw ④ in the feed support plate ⑦ appears.
- 3) Loosen screw ④ in the feed support plate ⑦ and adjust the height of the feed dog ⑥ by moving feed support plate ⑦ up or down.
- 4) After the adjustment, firmly tighten screw ④ in the feed support plate ⑦.

15. ADJUSTING THE NEEDLE-TO-SHUTTLE RELATIONSHIP



CAUTION

TURN THE SWITCH OFF THE POWER SUPPLY TO PREVENT FROM UNEXPECTED INJURY. BE SURE TO CONFIRM THE STOP OF ROTATION OF THE MOTOR BEFORE OPERATIONS.

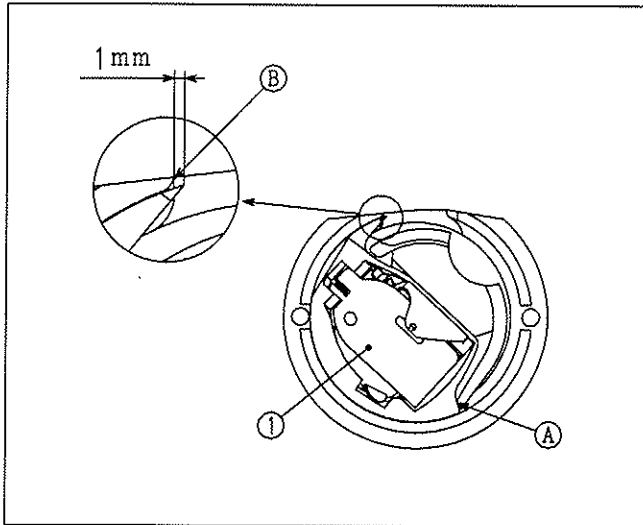

◆The position of the shuttle when it is recessed most.

When shuttle ① turns counterclockwise until it will go no further and the shuttle and the shuttle race come in contact with each other at point A, a distance of 1 mm should be provided between the blade point of the shuttle and end face B of the shuttle race.

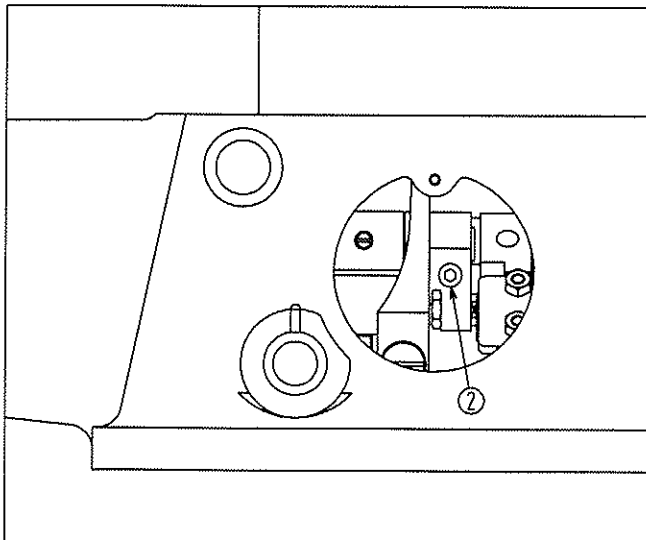

To adjust the position of the shuttle being pulled:

- 1) Turn the handwheel and stop turning when the shuttle turns counterclockwise until it will go no further.
- 2) Loosen screw ②.
- 3) Align the blade point of the shuttle by turning the shuttle by hand.
- 4) After adjustment has been completed, tighten screw ② firmly.

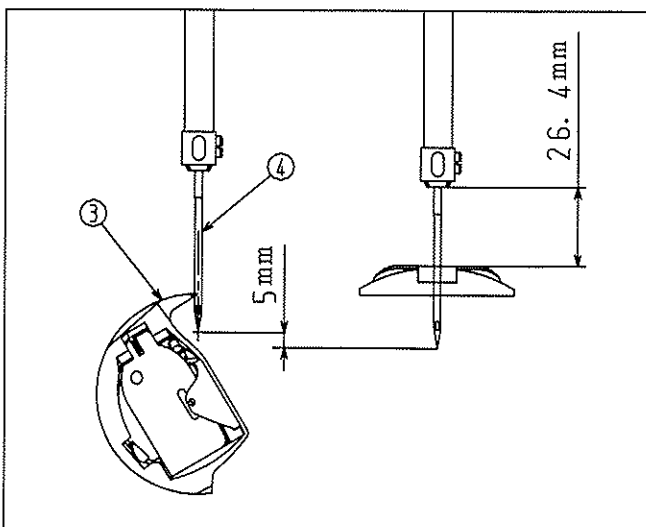

◆Positioning the needle and shuttle

Turn the handwheel to make the needle bar ascend 5 mm from its lowest position. At this time, blade point ③ of the shuttle should be aligned with the center of needle ④.

(Reference value of the lowest position of the needle bar stroke)
The distance from the upper surface of the throat plate to the lower end of the needle bar should be 26.4 mm

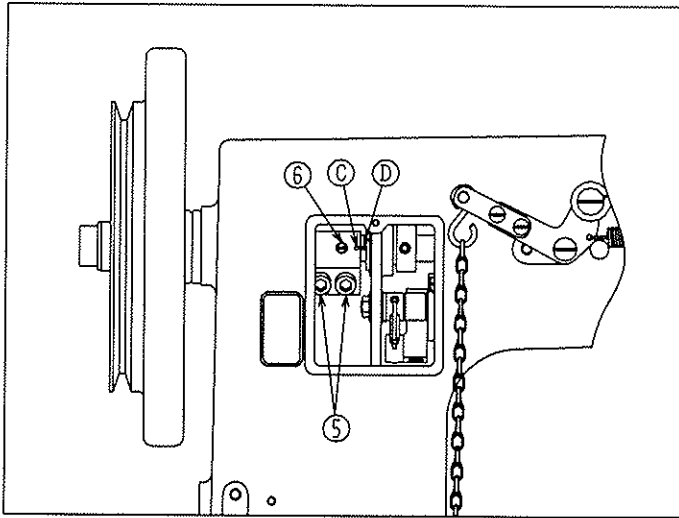

To adjust the position of the needle and shuttle

- 1) Loosen screw ⑤.
- 2) Loosen screw ⑥, and adjust so that marker dot ③ engraved on the eccentric cam of the vertical rod is aligned with marker line ④ engraved on the main shaft. Then, tighten screw ⑥.
- 3) Turn the handwheel toward you, and check the lifting amount of the needle bar.
- 4) After the adjustment, securely tighten screws ⑤ and ⑥.

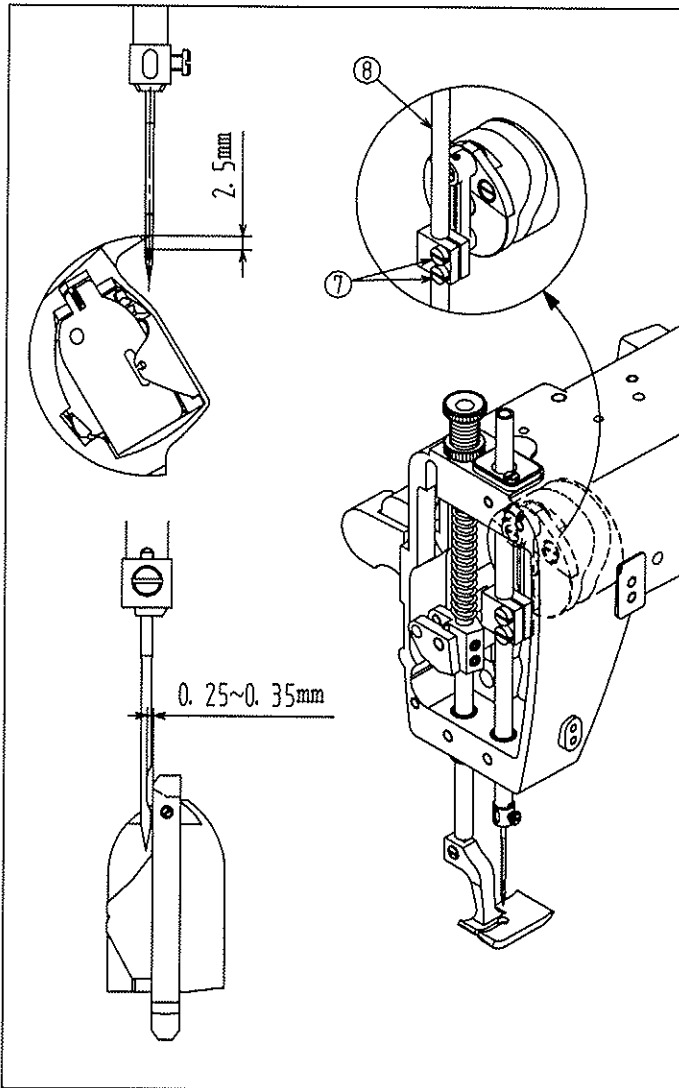

◆The height of the needle bar

The correct height is that the distance from the blade point of the shuttle to the upper end of the needle eyelet is 2.5mm when the blade point of the shuttle is aligned with the center of the needle.

To adjust the height of the needle bar

- 1) Turn the handwheel and stop turning it when the blade point of the shuttle is aligned with the center of needle.
- 2) Loosen screws ⑦.
- 3) Adjust the height by moving needle bar ⑧ up and down.
- 4) After adjustment has been completed, firmly tighten screws ⑦.

◆The needle-to-shuttle clearance

The clearance between the recess in the needle and the blade point of the shuttle has already been adjusted to 0.25~0.35mm.

Point of the shuttle has already been adjusted to 0.35mm.

Adjust the clearance between the needle and the shuttle by replacing the shuttle race back.

(The shuttle race back comes in six different thickness in addition to the standard thickness.)

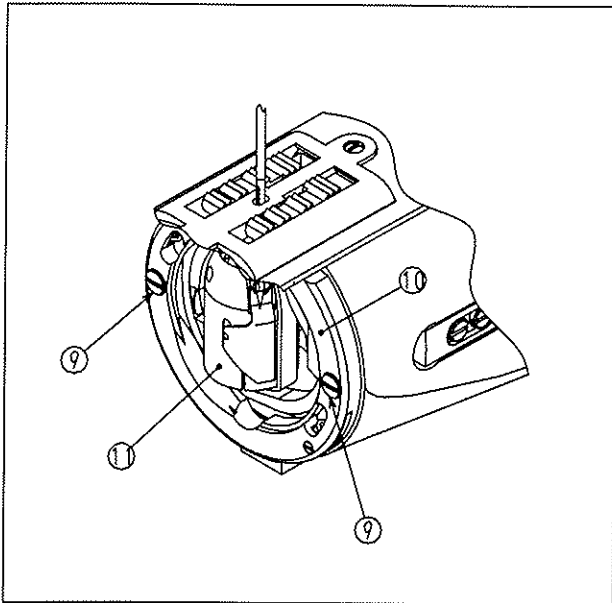

To replace the shuttle race back

1) Remove two screws (9) in the shuttle race, remove shuttle race (10), and remove shuttle (11).

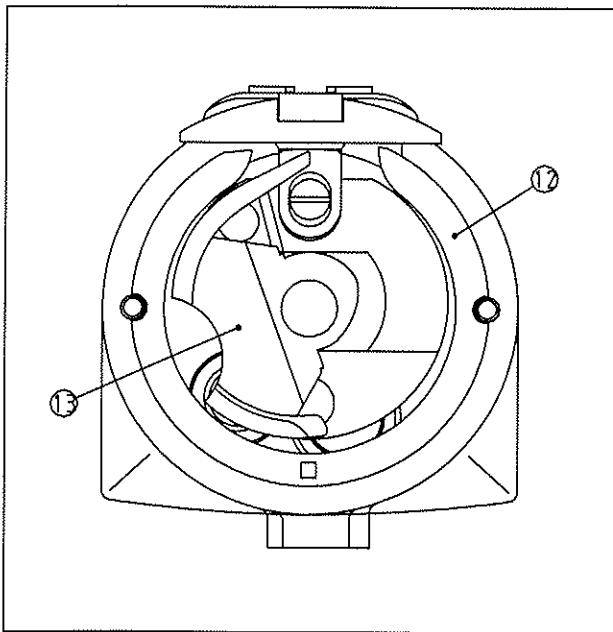

2) Turn the handwheel until shuttle driver (13) is brought to the position where shuttle race back (12) comes off. Then replace the shuttle race back.

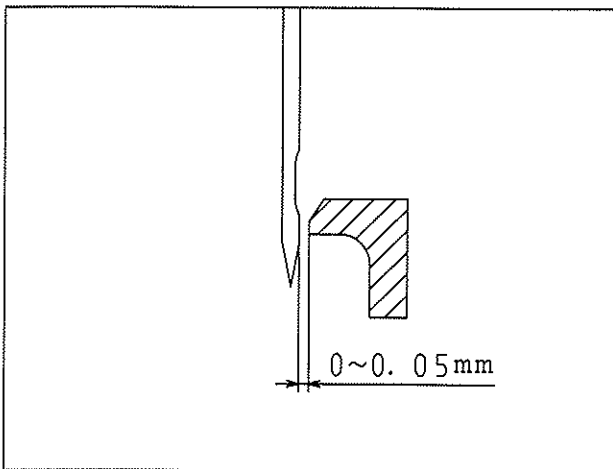

◆Clearance between the needle and the shuttle driver

The clearance between the needle and the needle guide of the shuttle driver has already been adjusted to the range of 0 through 0.05mm

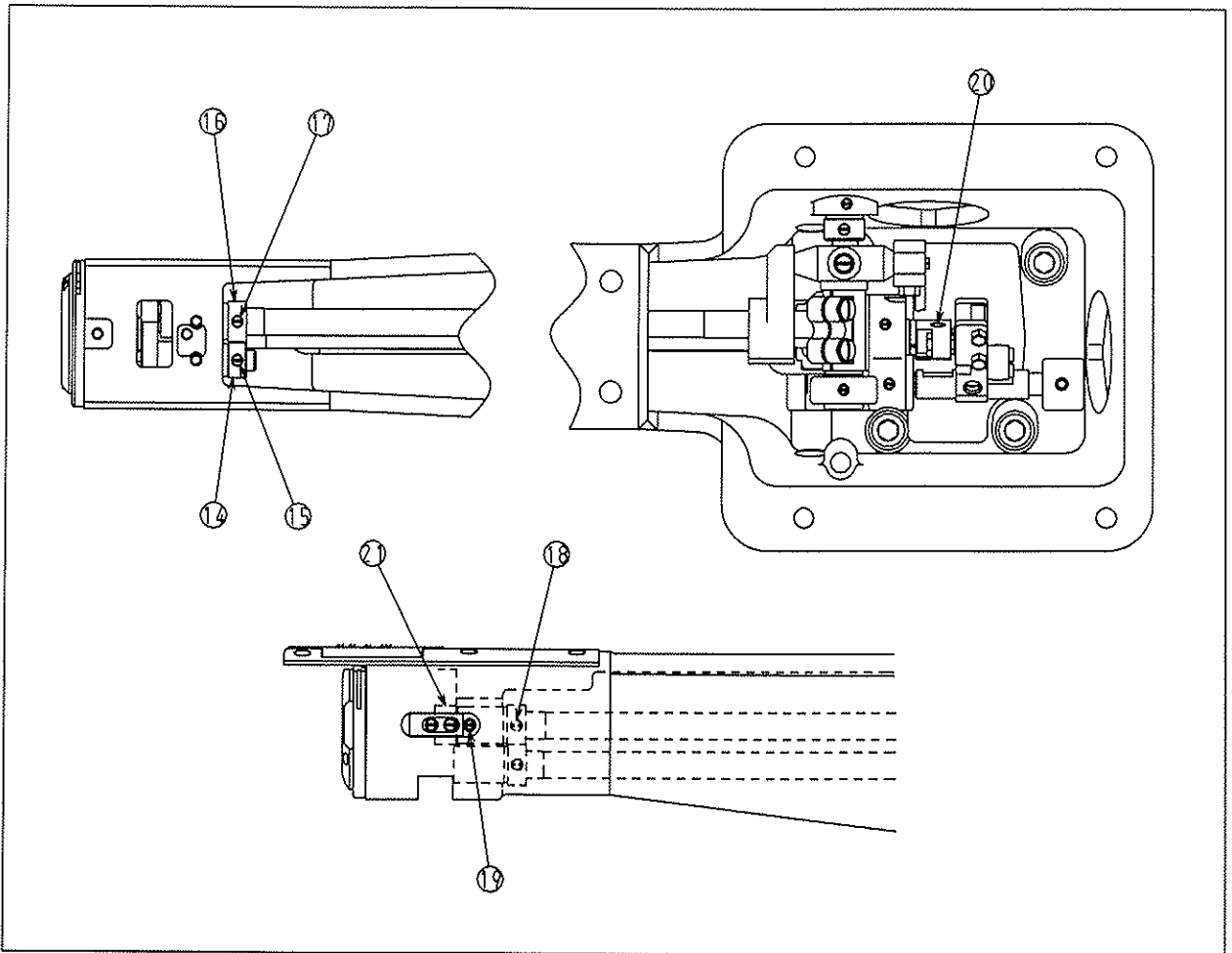

To adjust the clearance between the needle and the shuttle driver

- 1) Loosen two screws 15, and remove thrust collar 14 of the feed rock driving shaft on the feed bracket.
- 2) Loosen two screws 17, and move thrust collar 16 of the feed rock shaft.
- 3) Loosen two screws 18 in the shuttle driving shaft thrust collar, screw 19 in the shuttle driving shaft front bushing and small pendulum clamping screw 21.
- 4) Adjust the clearance by moving shuttle driving shaft front bushing 21 to the left and right.
- 5) After the adjustment has been completed, secure the shuttle driving shaft thrust collar and the small pendulum, making sure there is no axial play of the shuttle driving shaft.
- 6) Finally, secure the respective thrust collars, making sure there is no play in the feed driving shaft and the feed rock shaft.

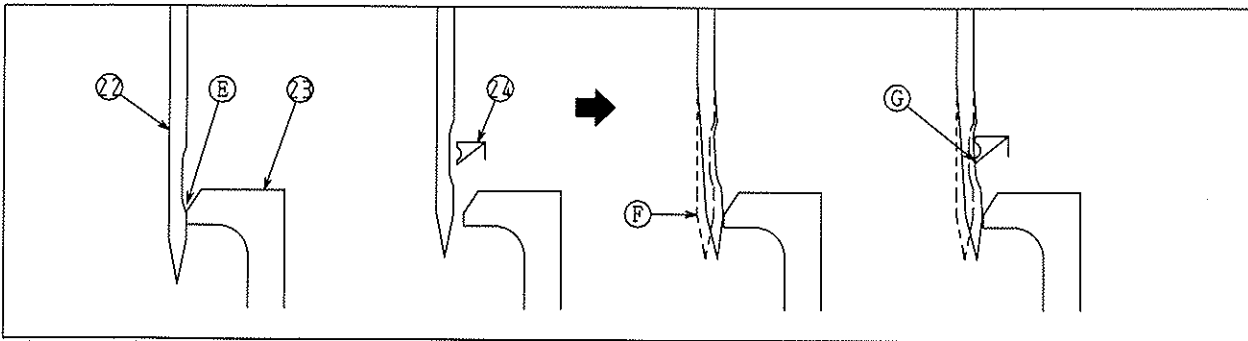

The standard for adjusting the clearance between the needle and the blade point of the shuttle

Use a standard Schmetz 794-Nm 230 needle.

- 1) Adjust the clearance (E) between the convex section of needle (Z2) and shuttle driver (Z3) to 0.
- 2) Align the needle center with the blade point of shuttle (Z4) and press the (F) section of the needle against the shuttle driver.
- 3) Adjust the clearance (G) to a minimum with the needle pressed against the shuttle driver, making sure that the needle does not contact the blade point of the shuttle.

*By this adjustment the needle-to-shuttle blade point clearance will be 0.25~0.35mm

16. THE FEED DOG-TO-NEEDLE RELATIONSHIP

CAUTION TURN THE SWITCH OFF THE POWER SUPPLY TO PREVENT FROM UNEXPECTED INJURY. BE SURE TO CONFIRM THE STOP OF ROTATION OF THE MOTOR BEFORE OPERATIONS.

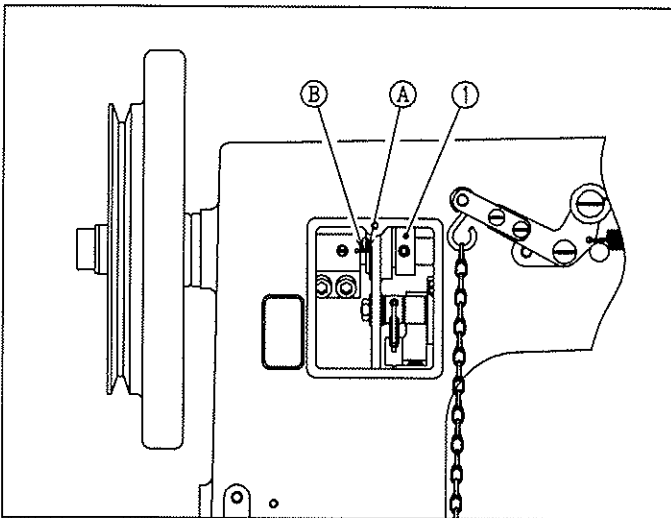



The standard timing between the feed dog and the needle is obtained when the feeding motion starts at the same time when the needle starts descending from its highest dead point.

◆To adjust the timing between the feed dog and the needle, follow the procedure stated below

- 1) Loosen the two screws in feed eccentric cam (C).
- 2) Align marker line (A) engraved on the side plate of the feed eccentric with marker line (B) engraved on the main shaft to obtain the standard timing.
- 3) After the adjustment, securely tighten the two screws in the feed eccentric cam.

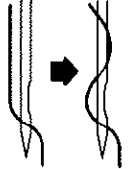
17. PROBLEMS WITH SEWING AND CORRECTIVE MEASURES

Problem	Cause	Corrective measures
1. Thread often breaks or thread splits finely, correct stitch cannot be formed (half-finished stitch)	<ol style="list-style-type: none"> 1) Flaw is found out at thread path, needle point, shuttle blade point, or needle eyelet. 2) Improper finish around the recess in the needle. 3) Excessively tightened needle thread tension. 4) The needle interferes with the blade point of the shuttle. 5) The timing of the needle and the shuttle is too early or too slow 6) Due to heat generated by the needle. 7) Excessive height difference at stepped section. 	<ul style="list-style-type: none"> • Remove flaw by smoothing flow with fine paper file. • Replace the needle with a new one. • Adjust the needle thread tension. • Refer to '15. ADJUSTING THE NEEDLE-TO-SHUTTLE RELATIONSHIP'. • Refer to '15. ADJUSTING THE NEEDLE-TO-SHUTTLE RELATIONSHIP'. • Decrease the sewing speed of the machine. Use silicone oil. • Increase the amount of movement of the thread take-up spring.
2. Stitches are frequently skipped	<ol style="list-style-type: none"> 1) The needle-to-shuttle blade point clearance is excessive. 2) The timing of the needle and the shuttle is too early or too slow. 3) The presser bar pressure is insufficient. 4) The distance from the upper end of the needle eyelet to the blade point of the shuttle is not proper. 5) The needle is improperly selected. 6) The amount of movement of the thread take-up spring is excessive. 7) Overheated needle or shuttle. Thread is not pulled smoothly. 8) Reverse stitching is made at low speed on light weight material using nylon thread. 	<ul style="list-style-type: none"> • Refer to '15. ADJUSTING THE NEEDLE-TO-SHUTTLE RELATIONSHIP'. • Refer to '15. ADJUSTING THE NEEDLE-TO-SHUTTLE RELATIONSHIP'. • Tighten the presser adjuster screw. • Refer to '15. ADJUSTING THE NEEDLE-TO-SHUTTLE RELATIONSHIP'. • Replace the needle with a one-count lower needle. • Decrease the amount of movement of the thread take-up spring. • Use silicone oil. • Wind the needle thread around the needle. 
3. Improper thread tension, irregular stitch, excessive bobbin thread tension	<ol style="list-style-type: none"> 1) Poor finish of the thread path. 2) The bobbin slides unsmoothly. 3) Weak bobbin thread tension. 4) Bobbin thread is wound too tightly. 5) Needle thread flaps. (Needle thread flaps and comes out of the thread tension disc due to excessive needle thread tension or is caught in other parts.) 6) Too thin bobbin thread is used to combine with needle thread. 	<ul style="list-style-type: none"> • Smooth the surface with a fine paper file or using a buff. • Replace the bobbin or the shuttle. • Adjust the bobbin thread tension. • Decrease the tension of the bobbin in thread winder. • Thread the tension guide bar as illustrated right. • Use silicone oil. 
4. Poor gloss of the needle thread	<ul style="list-style-type: none"> • Excessive height difference at stepped section. 	<ul style="list-style-type: none"> • Use silicone oil.
5. The belt slips (Motor stoppage occurs, if an electric is used.)	<ol style="list-style-type: none"> 1) The V belt is degraded. 2) The V belt tension is not enough. 	<ul style="list-style-type: none"> • When degradation is found out to the V belt as wear, cracking, etc., replace with a new one. • Adjust the slack amount in the V belt to 10 mm/1 kgf. 