

GOLDEN WHEEL

No. 004033

CSU-4150-BT	1-NEEDLE , UNISON FEED, LOCKSTITCH MACHINE WITH AUTOMATIC THREAD TRIMMER
CSU-4250-BT	2-NEEDLE , UNISON FEED, LOCKSTITCH MACHINE WITH AUTOMATIC THREAD TRIMMER

Please read this Instruction Manual carefully before using the unit in order to get the most out of it and to enjoy using it for a long time . Please keep this Instruction Manual at hand taking care not to lose it .

INSTRUCTION MANUAL

BEFORE OPERATION

1. Do not operate the machine even for trial before lubrication it .
2. Confirm that the voltage and phase (single or 3-phase) are correct by checking them against the ratings shown on the motor nameplate .
3. When running your machine for the first time after the set-up, check the rotational direction of the handwheel . ★ Turn on the power switch . Run the machine at a low speed while checking the rotational direction of the handwheel . (The handwheel should turn counterclockwise as observed from the handwheel side .)
4. For the first month, run the machine at speed of 1600s p m or less .

CAUTIONS IN OPERATION

1. Keep your hands away from the needle when you turn on the power switch or while the machine is operating .
2. During operation, be careful not to allow your or any other person's head or fingers to come close the handwheel, V-belt, bobbin winder or motor . Also do not place anything close to them .
3. Do not turn the machine with the finger guard, beltcover or any other protectors removed .
4. Be sure to turn off the power switch and confirm that the motor is completely stopped before removing the V-belt .

SPECIFICATIONS

Spec	Model	CSU-4150-BT	CSU-4250-BT
Application		Heavy material	
Sewing speed (Max)		2000 (spm)	
Stitch length		0~9 (mm)	
Needle bar stroke		36 (mm)	
Presser foot stroke	Knee lifter	16 (mm)	
	Hand lifter	8 (mm)	
Needle		DP×17 #23	
Lubricating oil		Machine oil (white spindle oil)	

1. MOUNTING POSITION OF THE KNEE LIFTER

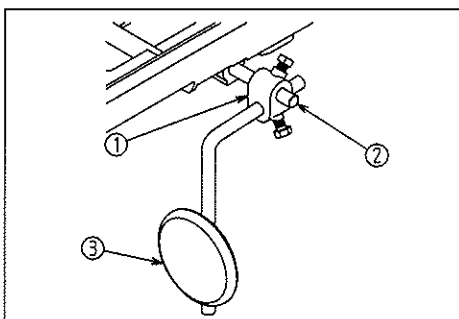

- 1) Insert knee lifter crank ① in the knee lifter shaft ② .
- 2) Attach knee lifter plate rod asm. ③ to the knee lifter crank ① .

2. LUBRICATION (1)

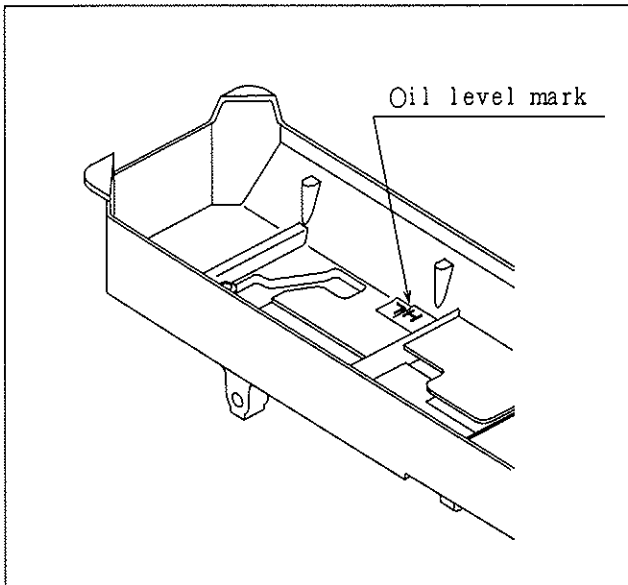

Fill the oil reservoir with oil up to 'H' mark. Oil level should be periodically checked. If oil level is found below 'L' level, replenish oil to 'H' level. Using oil is white spindle oil.

3. LUBRICATION (2)

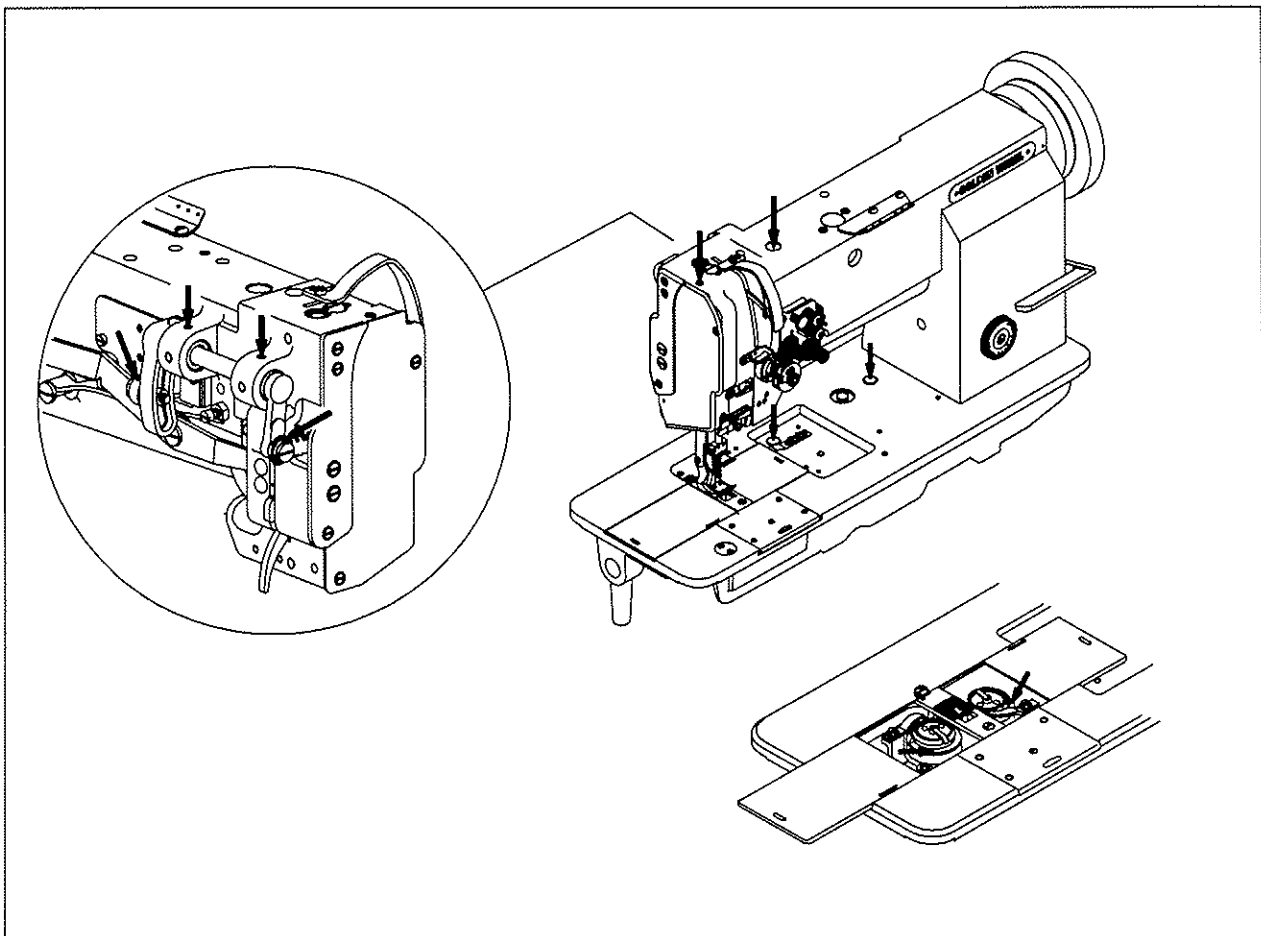

Before starting the machine.

1) Prior to operation, be sure to properly lubricate the points marked with the arrows.

When oiling all sections requiring lubrication, after installation of the machine has been completed, wait for a while (approximately 10 minutes) so that oil can penetrate each section sufficiently before starting continuous operation.

When starting the machine initially and after kept away for a long time without using at all, apply two or three drops of oil each section noted with an arrow mark, and to operate the machine continuously, apply two or three drops of oil each section whenever starting operation in the morning and in the afternoon.

4. OILING CONDITION

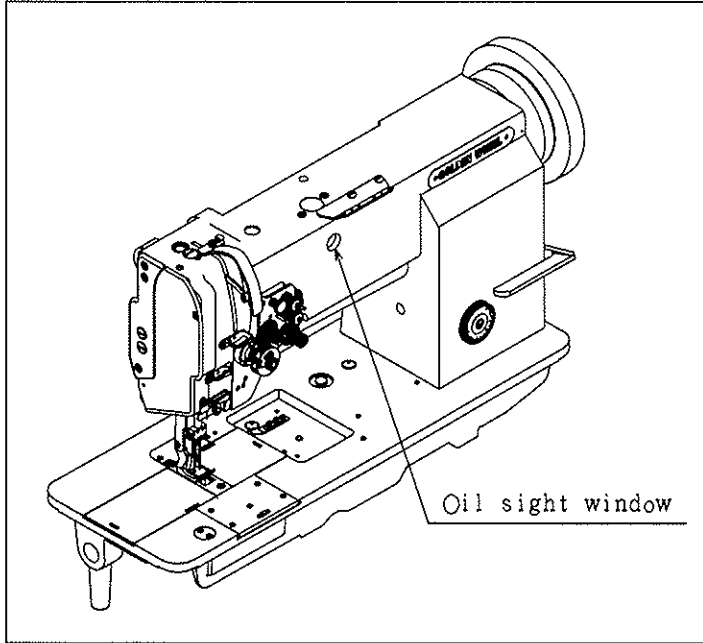

1) See dripping of oil during operation through the oil sight window to check oiling condition in the machine arm.

5. REFUELING ADJUSTMENT OF THE HOOK

 CAUTION	TURN THE SWITCH OFF THE POWER SUPPLY TO PREVENT FROM UNEXPECTED INJURY. BE SURE TO CONFIRM THE STOP OF ROTATION OF THE MOTOR BEFORE OPERATIONS.
--	--

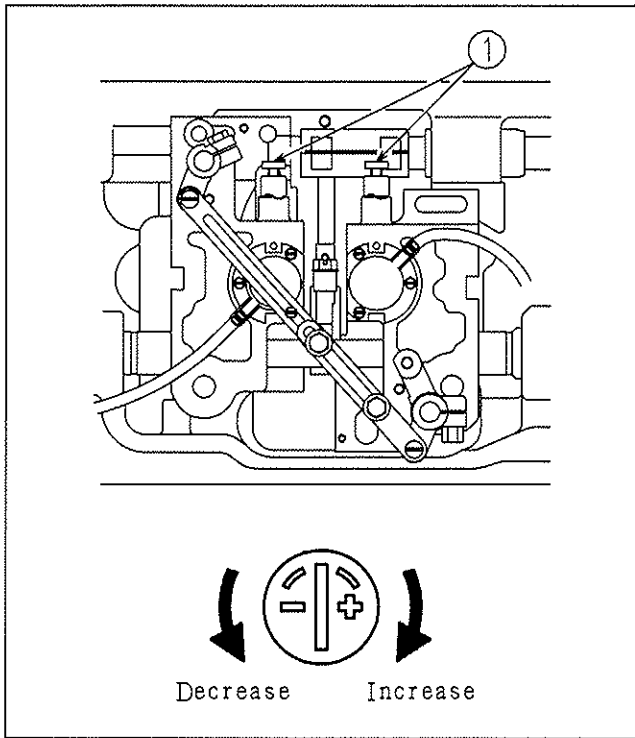

If it is necessary to change the amount of oil supplied to the hook, adjust it using knob ①.

- Turn the knob clockwise (in direction "+") to increase the oil supplied, or turn it counterclockwise (in direction "-") to decrease it.

Attention:
After adjusting the knob and no-load running more than 30 seconds, confirm oil which scatters from the hook.

6. INSTALLATION OF NEEDLES



CAUTION

TURN THE SWITCH OFF THE POWER SUPPLY TO PREVENT FROM UNEXPECTED INJURY. BE SURE TO CONFIRM THE STOP OF ROTATION OF THE MOTOR BEFORE OPERATIONS.

Double Needle

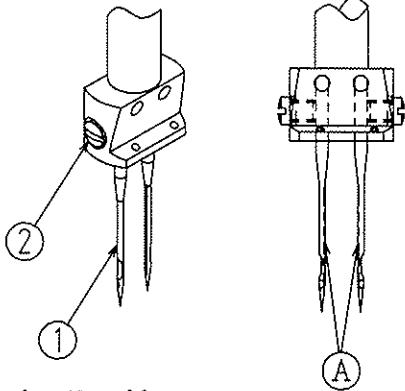

Single Needle

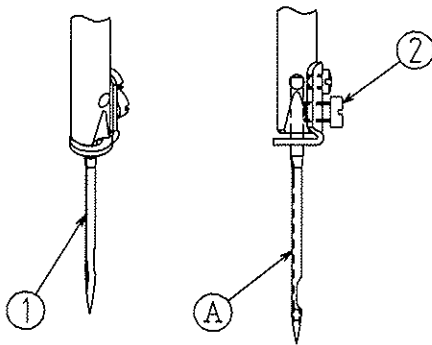

- 1) Turn the handwheel to move the needle bar up to its highest position.
- 2) Loosen needle setscrew ②, and hold needle ① so that long groove ① oppositely each other. (For Double needle) And so that long groove ① left side. (For Single needle)
- 3) Insert the needle into the needle bar until it will go no further.
- 4) Securely tighten the needle set screws ②.

7. WINDING OF BOBBIN THREAD



CAUTION

TURN THE SWITCH OFF THE POWER SUPPLY TO PREVENT FROM UNEXPECTED INJURY. BE SURE TO CONFIRM THE STOP OF ROTATION OF THE MOTOR BEFORE OPERATIONS.

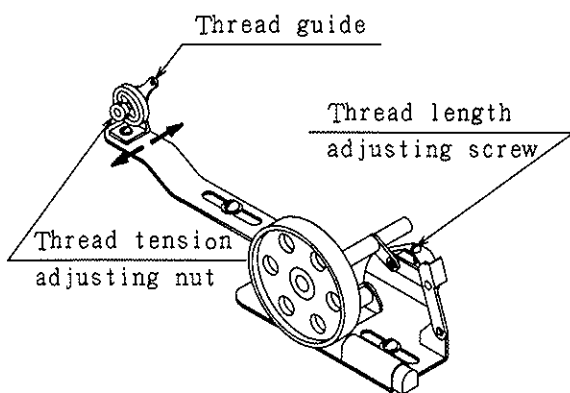

- Tension of wound thread
Slack winding is recommended for polyester thread and nylon thread.
- Conically wound thread
Move the thread guide to ward smaller diameter of wound thread layer.
- Length of wound thread
Loosen the thread length adjusting screw to increase length of thread and tighten the screw to decrease length of thread.

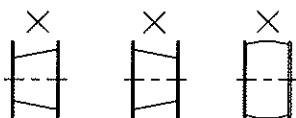

Bobbin should be filled with cylindrically wound thread up to 80% of bobbin capacity.

8. THREADING THE MACHINE HEAD



CAUTION

TURN THE SWITCH OFF THE POWER SUPPLY TO PREVENT FROM UNEXPECTED INJURY. BE SURE TO CONFIRM THE STOP OF ROTATION OF THE MOTOR BEFORE OPERATIONS.

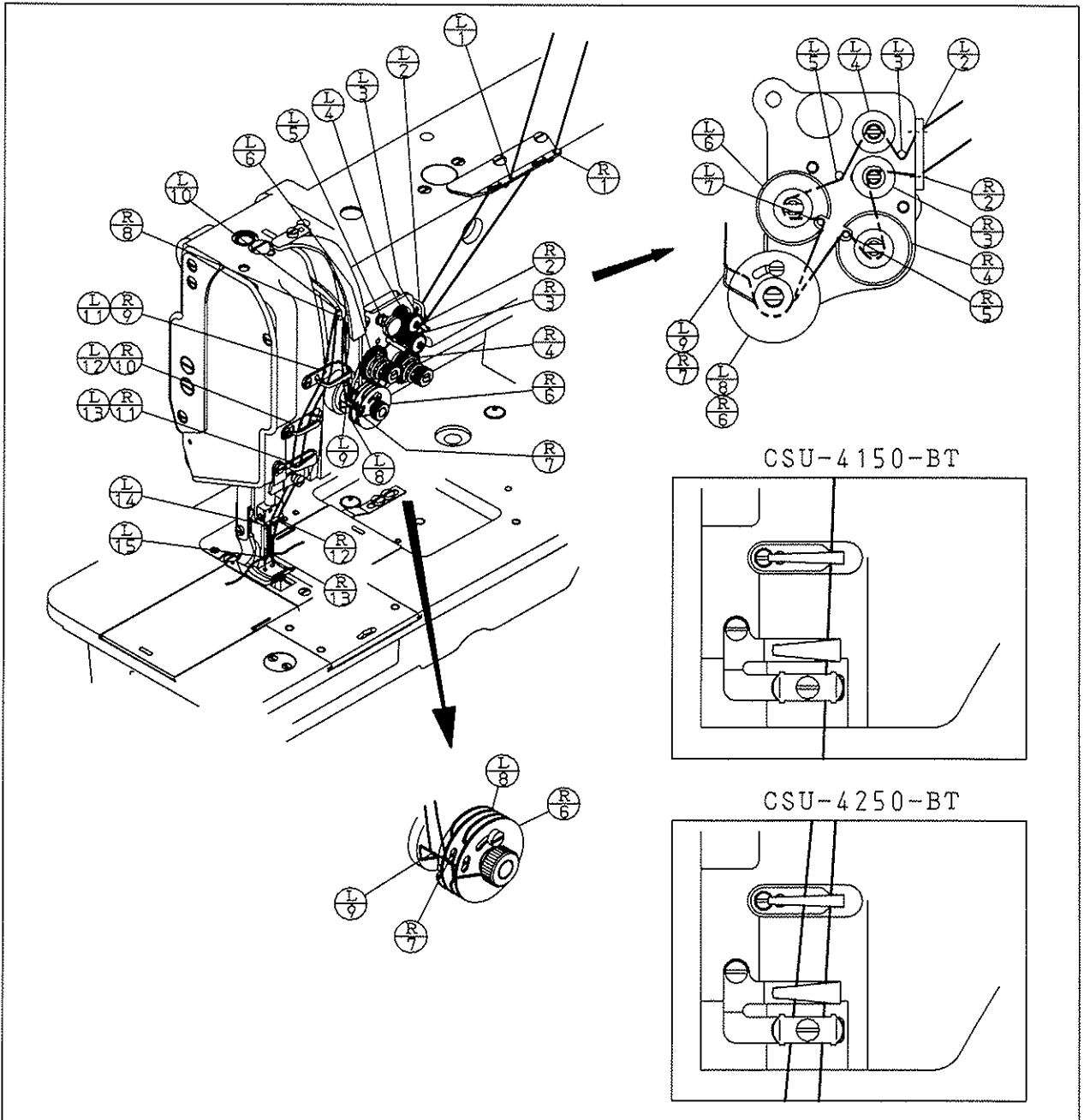

9. ADJUSTMENT OF STITCH LENGTH AND STITCH REVERSING (TOUCH-BACK)

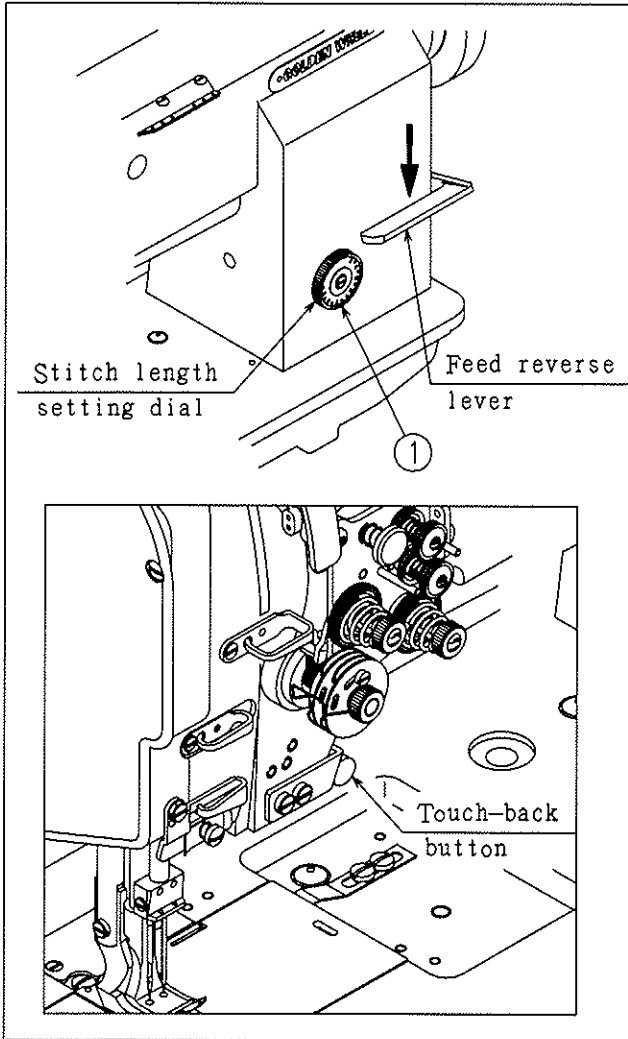

○ **Stitch length setting dial**
Turn the dial ①.

○ **Feed reverse lever**
How to operate

- 1) Push feed reverse lever down.
- 2) The machine performs reverse feed stitching as long as the lever is held depressed.
- 3) The moment you release the lever, the machine resumes the normal stitching mode.

○ **Touch-back button**
How to operate

- 1) The moment you press touch-back button, the sewing machine performs reverse feed stitching.
- 2) The machine continues reverse feed stitching as long as the touch-back button is held pressed.
- 3) When you release the switch, the machine resumes normal stitching.

10. THREADING OF BOBBIN THREADS

CAUTION

TURN THE SWITCH OFF THE POWER SUPPLY TO PREVENT FROM UNEXPECTED INJURY. BE SURE TO CONFIRM THE STOP OF ROTATION OF THE MOTOR BEFORE OPERATIONS.

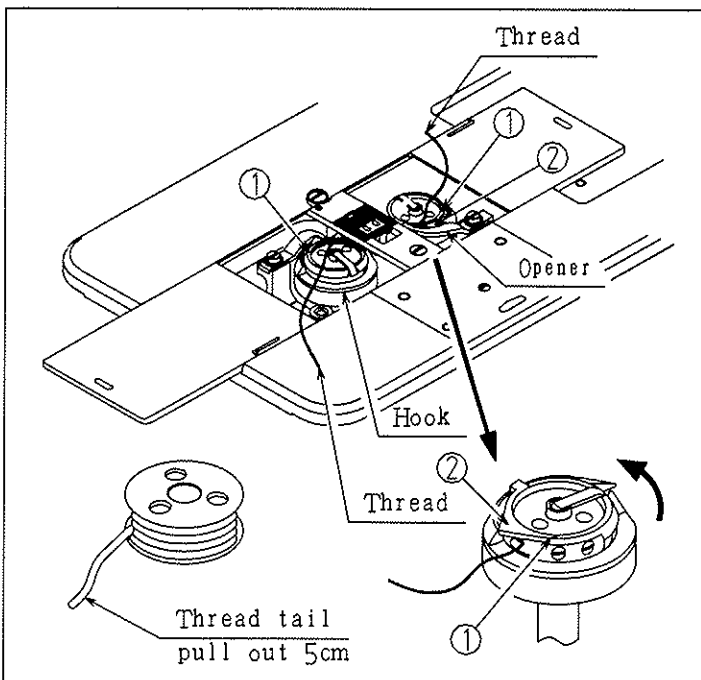

○ **Setting bobbin**

- 1) Pull out 5cm thread tail from the bobbin.
- 2) Hold the bobbin so that the bobbin thread is wound in right direction and put it into the hook.

○ **Threading of bobbin threads**

Put bobbin thread into the slit ①, pass under the lug ② and extend it below the bed.

NOTE: Fit the bobbin in the bobbin case so that the bobbin turns in the direction of the arrow when the bobbin thread is pulled.

11. THREAD TENSION



CAUTION TURN THE SWITCH OFF THE POWER SUPPLY TO PREVENT FROM UNEXPECTED INJURY. BE SURE TO CONFIRM THE STOP OF ROTATION OF THE MOTOR BEFORE OPERATIONS.

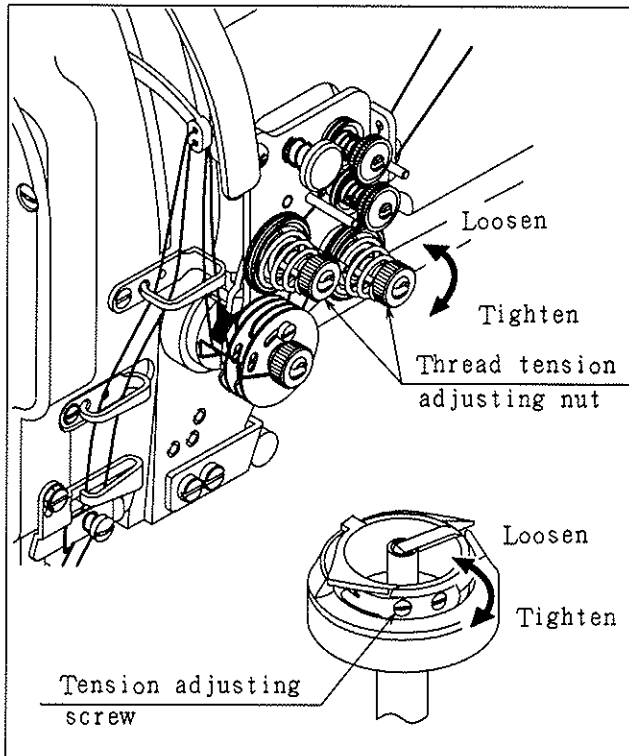

1) Adjusting the needle thread tension

Turn the thread tension adjusting nut clockwise to increase or counterclockwise to decrease the needle thread tension.

2) Adjusting the bobbin thread tension

Turn the tension adjusting screw clockwise to increase or counterclockwise to decrease the bobbin thread tension.

12. THREAD TAKE-UP SPRING



CAUTION TURN THE SWITCH OFF THE POWER SUPPLY TO PREVENT FROM UNEXPECTED INJURY. BE SURE TO CONFIRM THE STOP OF ROTATION OF THE MOTOR BEFORE OPERATIONS.

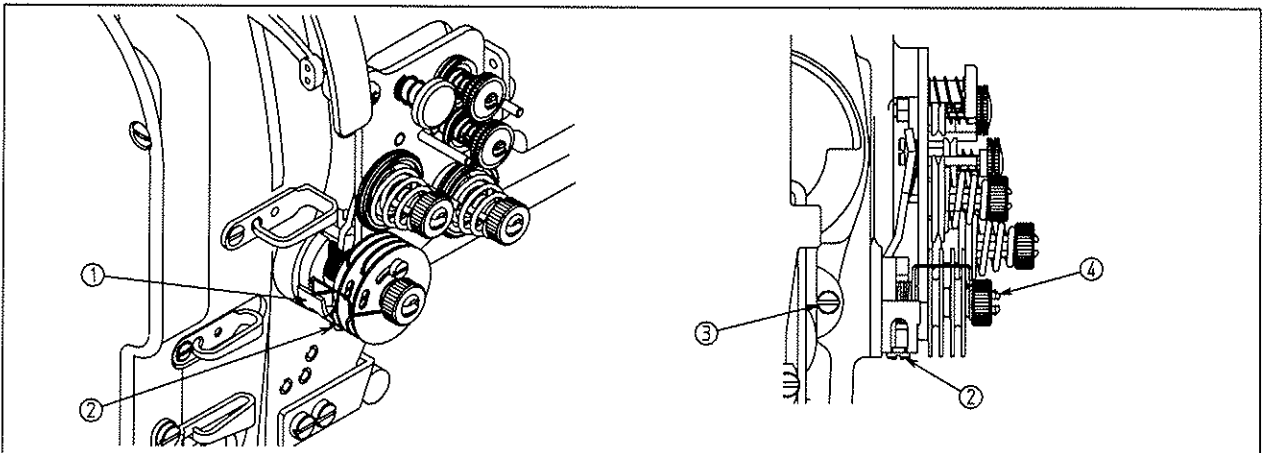

◇ Adjusting the thread take-up spring stroke

1. Loosen setscrew ②, and turn the adjusting plate ①.
2. Turn the adjusting plate ① to the right (counterclockwise), increase its moving range.
3. Turn the adjusting plate ① to the left, decrease its moving range.

◇ Adjusting the thread take-up spring tension

1. Loosen setscrew ③, and turn the tension stud ④ over toward left to increase tension.
2. Turn it to the right, decrease tension.
3. After adjustment, securely tighten the setscrew.

13. LIFTING THE PRESSER FOOT

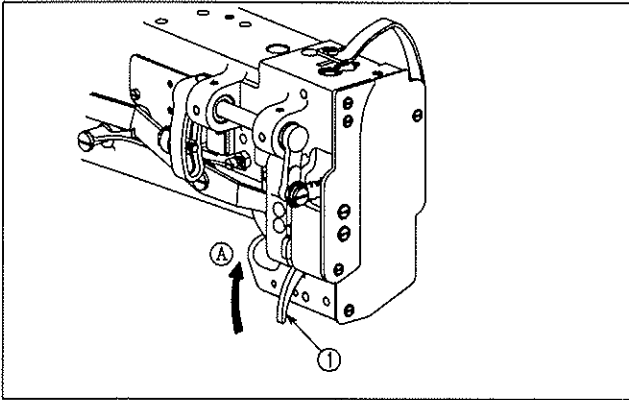

- 1) Turn the hand lifter ① toward ①, presser foot lifts 8 mm.
- 2) Using the knee lever, presser foot lifts 16 mm.

14. ADJUSTING THE PRESSER FOOT PRESSURE

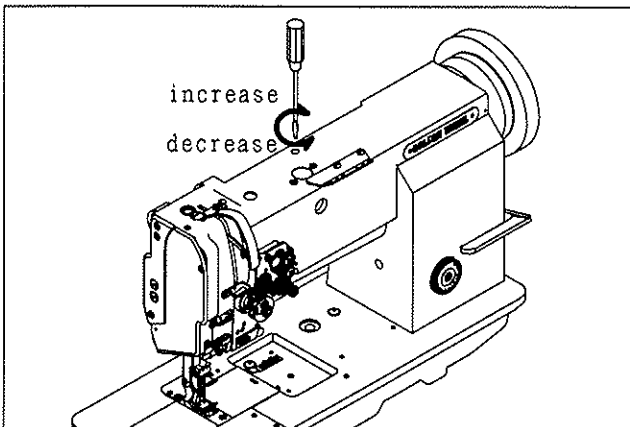

- 1) Turn the presser spring regulator to the right to increase and to the left to decrease pressure.

15. NEEDLE TO HOOK RELATIONSHIP



CAUTION

TURN THE SWITCH OFF THE POWER SUPPLY TO PREVENT FROM UNEXPECTED INJURY. BE SURE TO CONFIRM THE STOP OF ROTATION OF THE MOTOR BEFORE OPERATIONS.

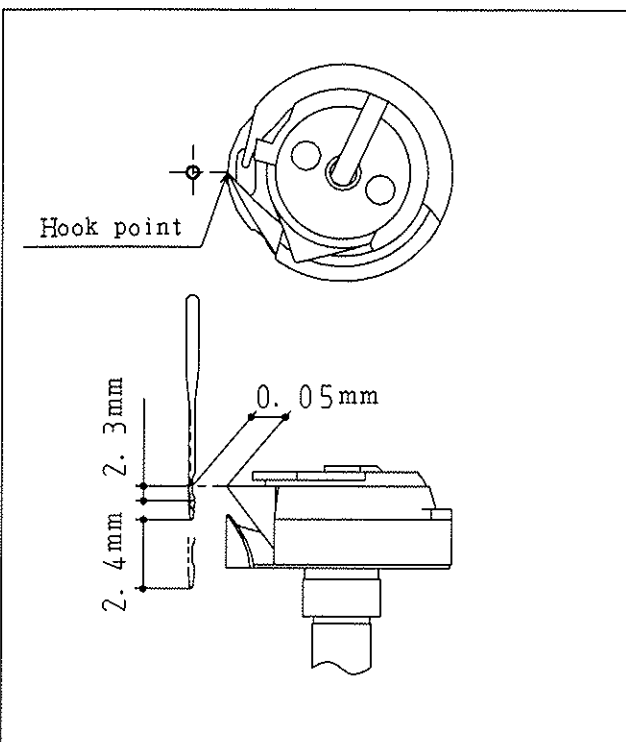

- (1) Set stitch length to "6" on the stitch length dial.
- (2) When needle is lifted 2.4 mm from the lowest position, the following positional relationship should be maintained.
 - The upper edge of needle eye should be 2.3 mm below the hook point.
 - The hook point should be located at the center of needle axis.
 - Gap between the hook point and the side face of needle should be 0.05 mm.
- (3) Needle rotating hook position can be adjusted as follows.
(For easy adjustment, it is recommended that the presser foot, throat plate and feed dog assemblies are removed.)

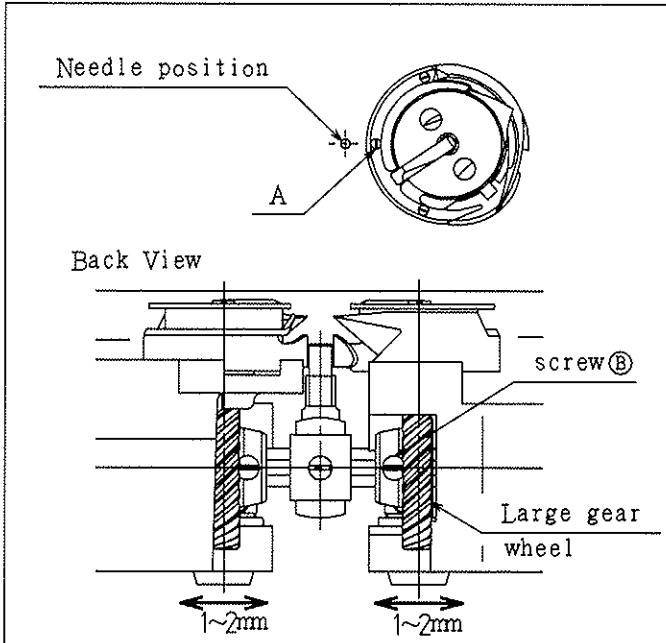

- **Position adjustment of hook point**
- (1) Approximate position of hook "A" screw of hook should be found close to the needle when the needle is at "DOWN" position.
 - (2) To finely adjust timing between the needle motion and hook motion, loosen the set screw of large gear wheel and move the gear wheel in its axial direction within a range from 1 mm to 2 mm.

Note: In the adjustment, do not excessively loosen set screws ⑥ and always maintain meshing of hook shaft gear and lower shaft gear.

16. ADJUSTMENT OF FEED DOG HEIGHT

⚠ CAUTION TURN THE SWITCH OFF THE POWER SUPPLY TO PREVENT FROM UNEXPECTED INJURY. BE SURE TO CONFIRM THE STOP OF ROTATION OF THE MOTOR BEFORE OPERATIONS.

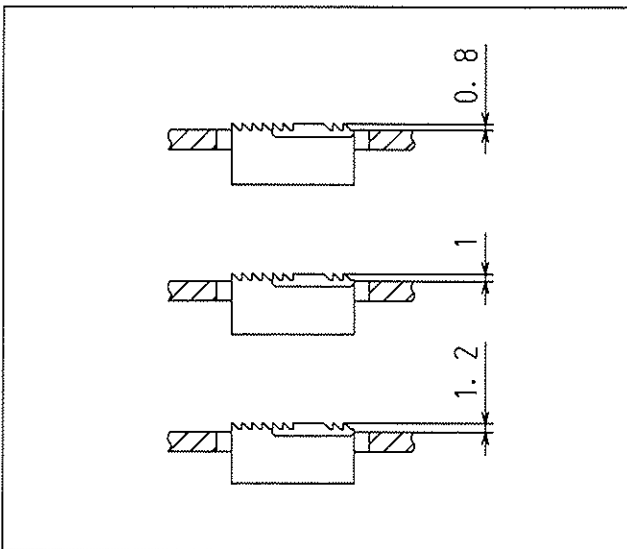

Height of feed dog and pressure of presser foot should be adjusted for individual fabric with the following cautions.

- ◆ Material will be damaged if the feed dog extends too high, or pressure of presser foot is too large.
- ◆ Even stitch length cannot be assured if the feed dog is too low or pressure of presser foot is too small.
- ◆ Feed dog height should be measured at the point where the needle is at the top position.

- For light materials ... Approx. 0.8mm from throat plate
- For usual materials ... Approx. 1.0mm from throat plate
- For heavy materials ... Approx. 1.2mm from throat plate

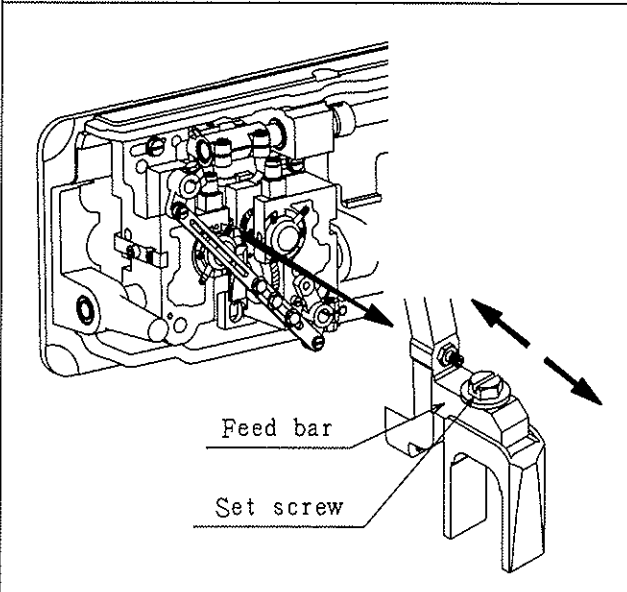

- **Adjustment procedure**
- (1) Lean the machine head backward.
 - (2) Turn the handwheel by hand and stop when the feed dog rises to the maximum height.
 - (3) Loosen the feed bar set screw.
 - (4) Vertically move the feed bar (in the direction indicated by arrow in the figure) to adjust it to adequate height.
 - (5) After the adjustment, tighten the feed bar set screw.

The feed dog height is factory-adjusted to ① mm shown table.

	Model	A (mm)
	CSU-4150-BT	1.2
	CSU-4250-BT	1.0

17. RELATIONSHIP BETWEEN ROTATING HOOK MOTION AND TAKE-UP LEVER MOTION



TURN THE SWITCH OFF THE POWER SUPPLY TO PREVENT FROM UNEXPECTED INJURY. BE SURE TO CONFIRM THE STOP OF ROTATION OF THE MOTOR BEFORE OPERATIONS.

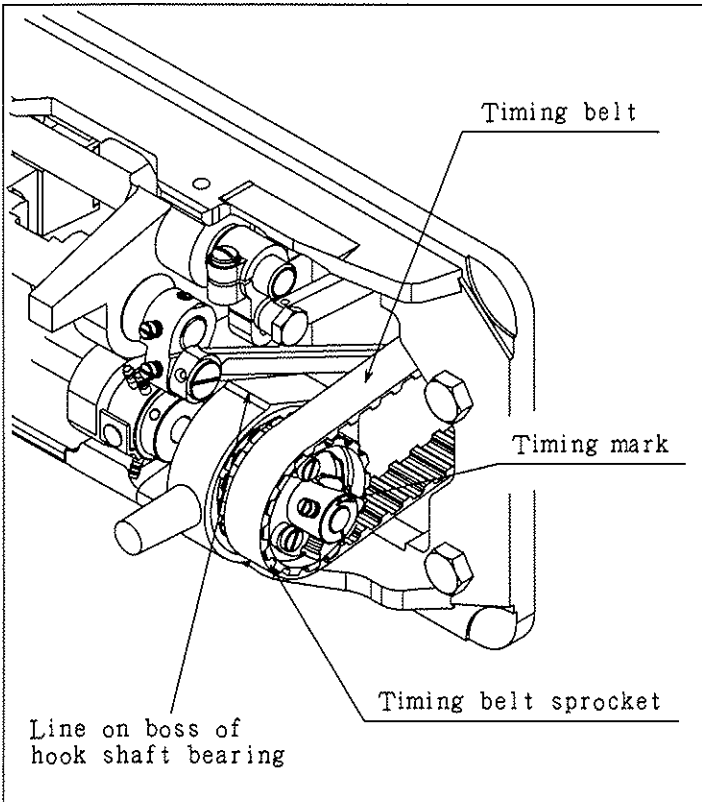

When the timing belt was removed for its replacement, for example, the relationship between rotating hook motion and take-up lever motion should be adjusted as follows :

- (1) Turn the handwheel and stop when the take-up lever is lifted to its top position.
- (2) Lean the machine head backward and make sure the arrow (timing mark) put on the timing belt is in line with the line on the boss of hook shaft bearing.
- (3) If the timing mark is not in line with the line on the boss, remove the timing belt and install it again to adjust.

18. RELATIONSHIP BETWEEN HOOK MOTION AND OPENER MOTION



TURN THE SWITCH OFF THE POWER SUPPLY TO PREVENT FROM UNEXPECTED INJURY. BE SURE TO CONFIRM THE STOP OF ROTATION OF THE MOTOR BEFORE OPERATIONS.

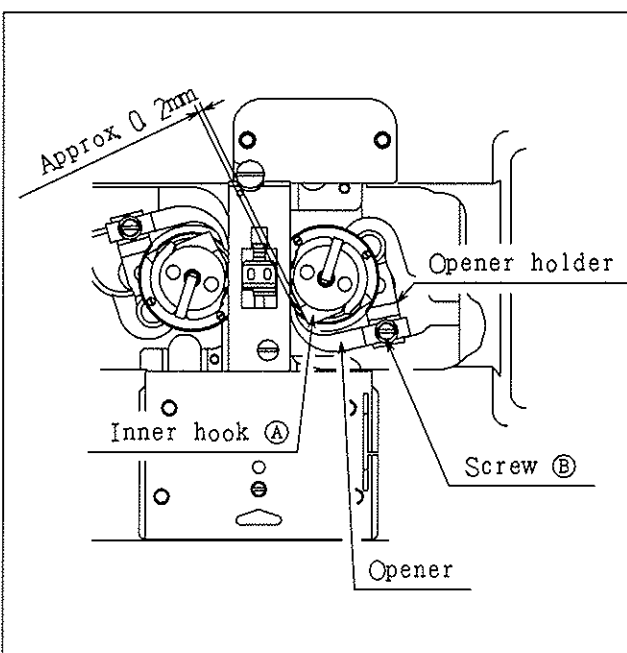

- (1) Turn the handwheel by hand and stop, when the opener holder is located most remotely from the throat plate.
- (2) Make sure gap between the inner hook (A) and the opener is approximately 0.2mm.
- (3) If the gap is too large or small, loosen the opener set screw (B) and adjust position of the opener.

19. RELATIONSHIP BETWEEN NEEDLE MOTION AND FEED DOG MOTION



CAUTION

TURN THE SWITCH OFF THE POWER SUPPLY TO PREVENT FROM UNEXPECTED INJURY. BE SURE TO CONFIRM THE STOP OF ROTATION OF THE MOTOR BEFORE OPERATIONS.

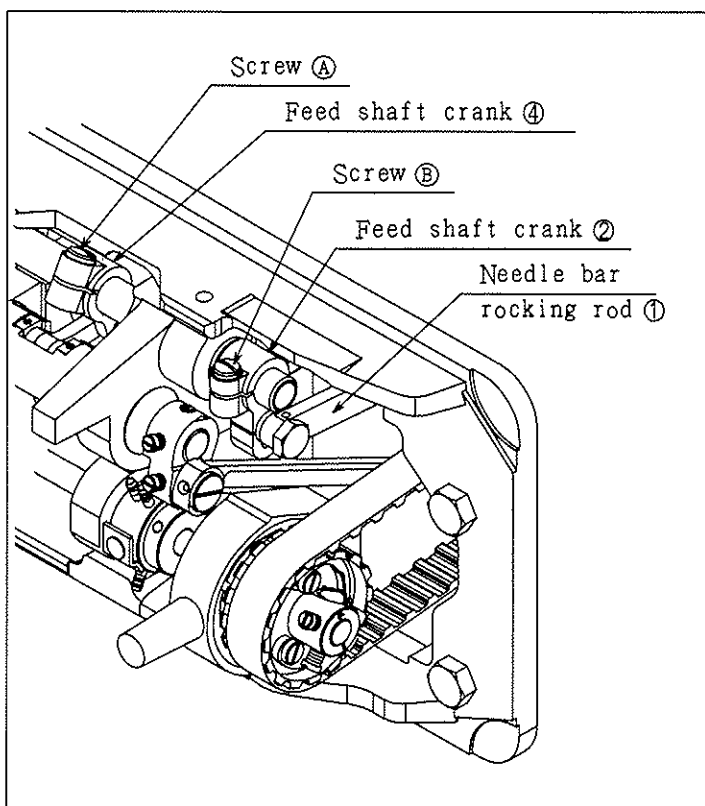

The feed dog should be adjusted so that the needle can plunge into the feed dog needle hole at the center of the hole.

- (1) Set stitch length to "0" on the stitch length setting dial.
- (2) Lean the machine head backward.
- (3) Loosen the feed shaft crank set screw A and B.
- (4) Set the needle at the lowest position.
- (5) Adjust the distance between the pressure bar and the needle bar to be 9 mm and tentatively tighten the screws A and B of the feed shaft crank.
- (6) Set stitch length to "9" on the stitch length setting dial. Turn the handwheel toward the right. Match the hinge screw C with the feed shaft crank 2 in horizontally at the most upper position.

● If the connection is not at the right position, remove the back cover, loosen the screw C and move the needle bar rocking rod 1 in the arrow direction, and adjust.

- (7) After the completion of adjustment, fully tighten the screws A, B and C.

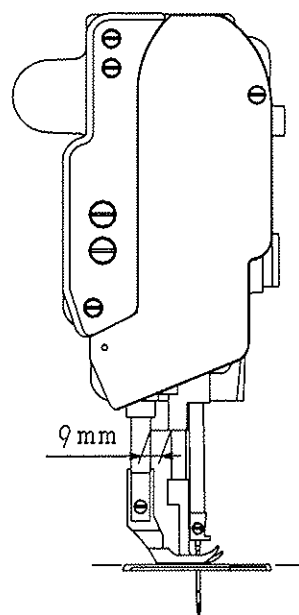
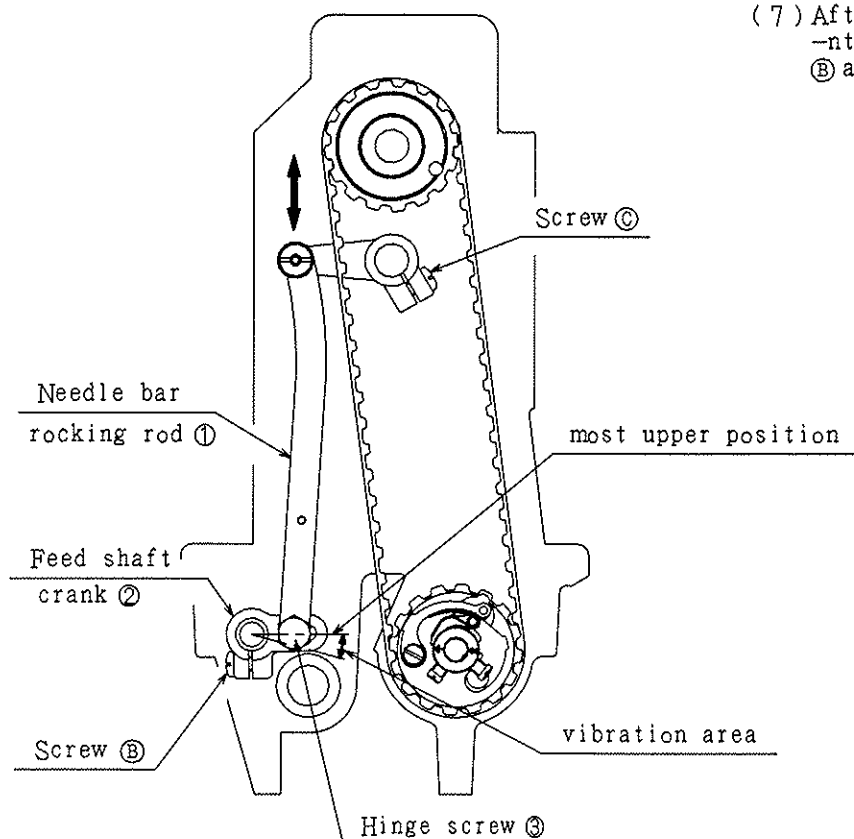

20. DIFFERENTIAL FEED MOTION OF THE NEEDLE BAR FRAME



CAUTION

TURN THE SWITCH OFF THE POWER SUPPLY TO PREVENT FROM UNEXPECTED INJURY. BE SURE TO CONFIRM THE STOP OF ROTATION OF THE MOTOR BEFORE OPERATIONS.

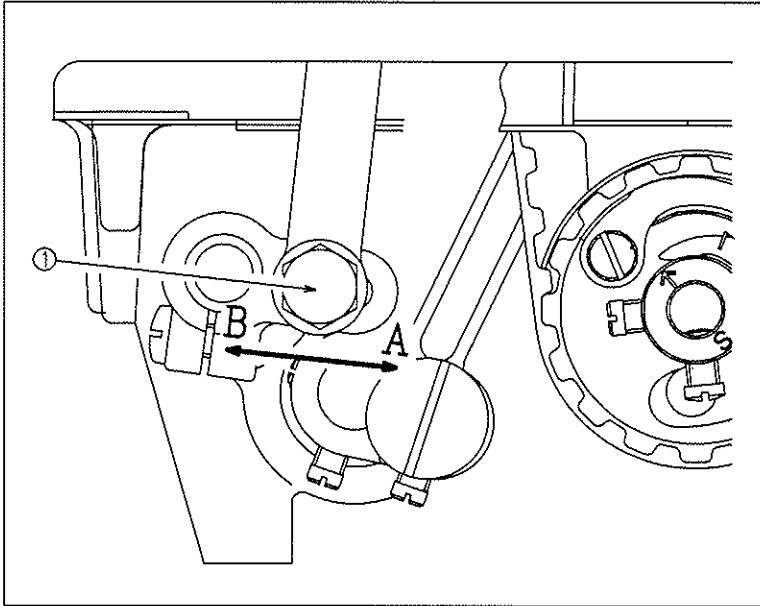

- 1) Loosen hinge screw ①. As you move it in direction "A", the stroke of the needle bar frame is increased, and differential feed with respect to the feed dog is provided. As you move it in direction "B", the stroke is decreased.

Precaution

Be sure to make this adjustment within the needle hole in the feed dog.)

21. RE-ENGAGE SAFETY CLUTCH MECHANISM



CAUTION

TURN THE SWITCH OFF THE POWER SUPPLY TO PREVENT FROM UNEXPECTED INJURY. BE SURE TO CONFIRM THE STOP OF ROTATION OF THE MOTOR BEFORE OPERATIONS.

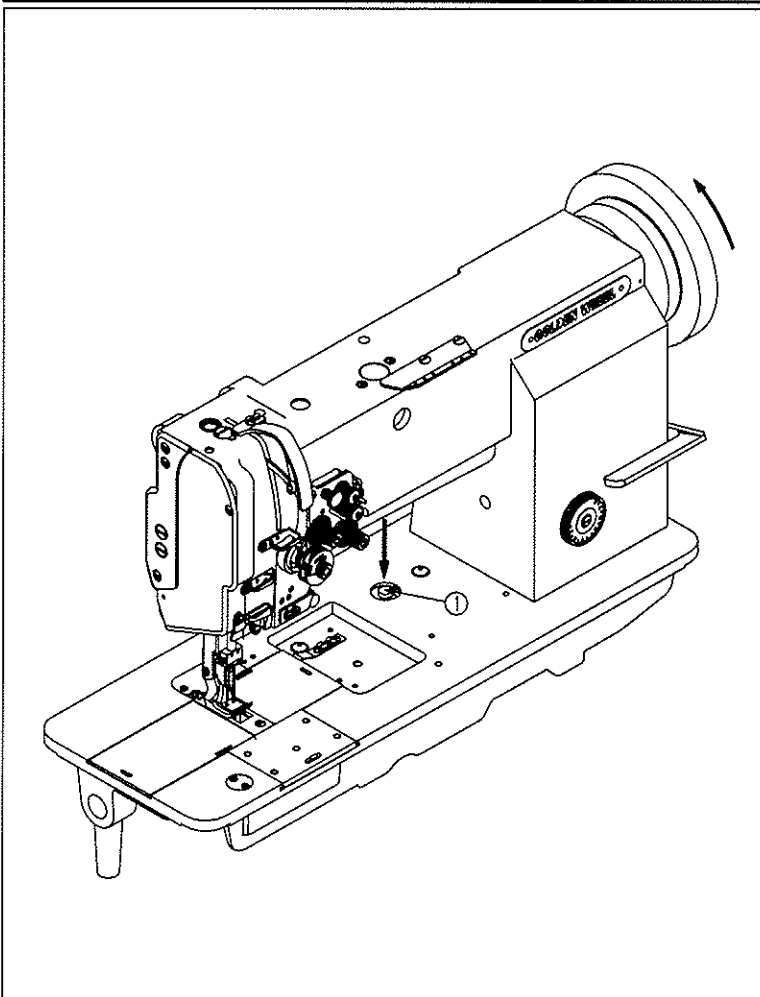

- 1) Remove any foreign matter which may have lodged in hook. Do not use any sharp-edged tools.
- 2) Pressing button ① and turn hand crank rearward slowly to re-engage safety clutch.

22. ADJUSTING THE WALKING FOOT



CAUTION

TURN THE SWITCH OFF THE POWER SUPPLY TO PREVENT FROM UNEXPECTED INJURY. BE SURE TO CONFIRM THE STOP OF ROTATION OF THE MOTOR BEFORE OPERATIONS.

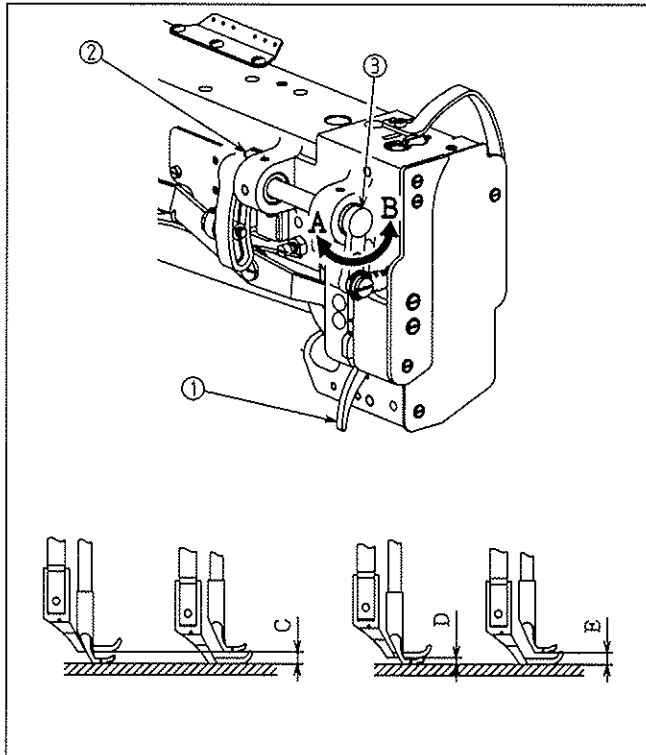

◇ Alternate vertical motions of the walking foot and the presser foot

- 1) The alternate vertical stroke of the walking foot and the presser foot are normally equal.
- 2) Depending on the type of material however, the vertical stroke of the presser foot and walking foot should be changed.
- 3) For instance, when sewing slippery material or sewing many overlapping sections, a better result may be obtained by adjusting the vertical stroke of the walking foot larger than that of the presser foot.

1 Turn the handwheel by hand until the thread take-up reaches its lowest point.

2 Lower hand lifter ①.

3 Loosen screw ②.

4 As you move top feed crank ③ to the left (in direction A), the vertical stroke of the presser foot decreases "D", whereas the vertical stroke of the walking foot increases "E".

5 On the contrary, as you move the top feed crank to the right (in direction B), the vertical stroke of the walking foot becomes closer "C" to that of the presser foot when the walking foot sole in contact with the throat plate surface.

6 After adjustment, securely tighten screw ②.

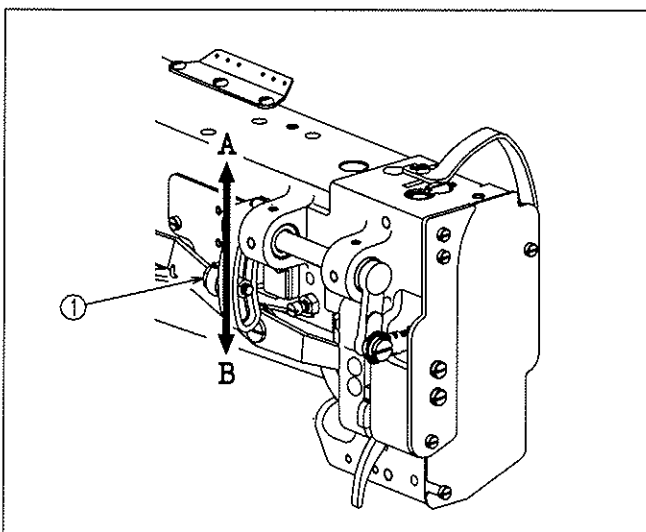

◇ Height of the walking foot and the presser foot

- 1) When sewing elastic material or overlapping sections, a better result may be obtained by changing the height of the presser foot and walking foot.

1 Loosen hinge screw ①.

2 When you move the cam rot boss toward "A" within the slot, the height is increased.

3 When you move it toward "B", the height is decreased.

4 After adjustment, securely tighten hinge screw ①.

23. INSTALLATION OF MOVABLE KNIFE



TURN THE SWITCH OFF THE POWER SUPPLY TO PREVENT FROM UNEXPECTED INJURY. BE SURE TO CONFIRM THE STOP OF ROTATION OF THE MOTOR BEFORE OPERATIONS.

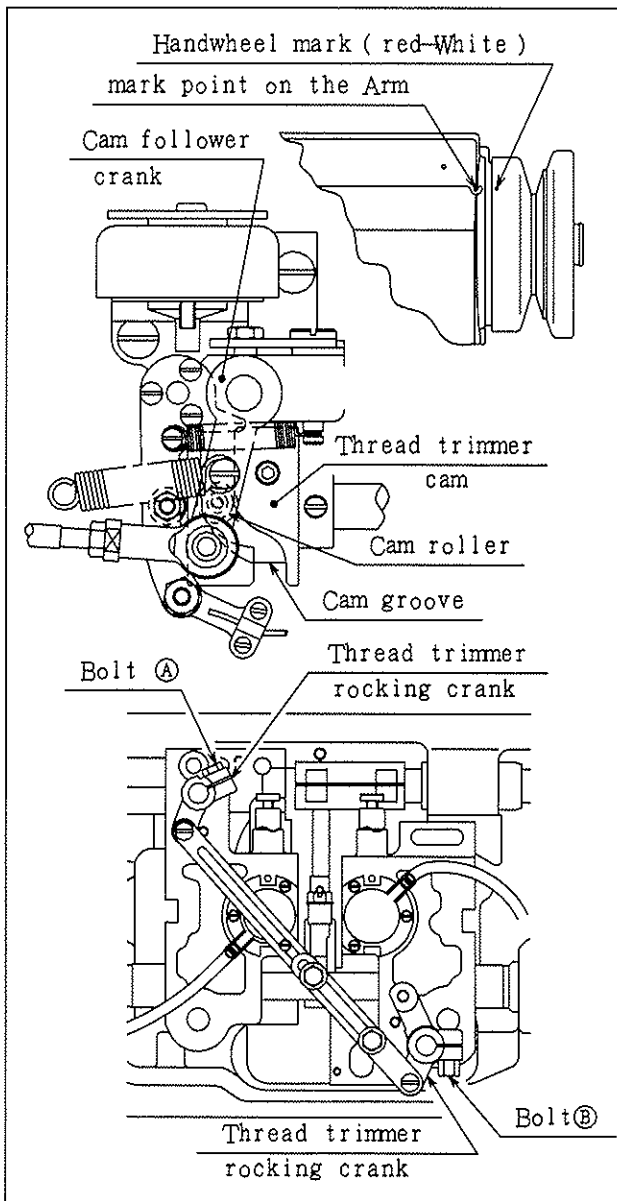

1 Initial position of movable knife

- (1) Turn the handwheel and lower the needle bar to the lowest position.
- (2) Push the cam follower crank so that the cam roller enters into the thread trimmer cam groove when the handwheel's mark red point meets the arm's point.
- (3) Turn the handwheel until the mark point on the arm meets the white mark point on the handwheel. Set the cam follower crank at the position with a screwdriver temporarily preventing the cam roller coming out from the cam groove.
- (4) Loosen the thread trimmer rocking crank clamp bolts ① and ②.
- (5) Adjust the movable knife so that the movable knife end slant portion protrudes 0~0.5 mm from the fixed knife, as shown in figure and tighten the bolts ① and ②.

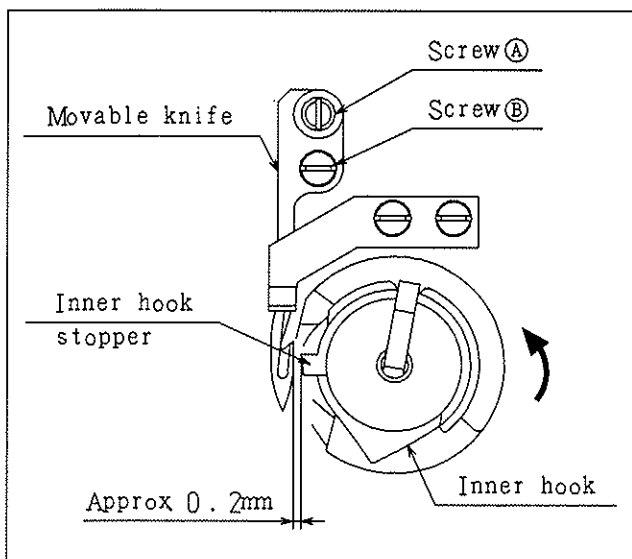
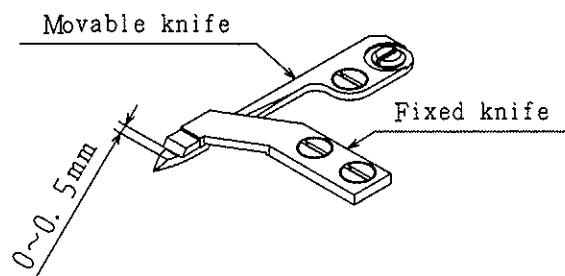

2 Gap between movable knife and inner hook stopper

- (1) Turn the handwheel by hand until the needle reaches the lowest position.
- (2) With the needle at the lowest position, depress cam follower crank, turn the handwheel until the movable knife reaches the extremity of its stroke.
- (3) Manually rotate the inner hook in the direction indicated by arrow in figure and adjust gap between the movable knife and the inner hook stopper to about 0.2 mm (the screws ① and ② should be loosened for this adjustment).

24. ADJUSTMENT OF THREAD TRIMMER CAM



CAUTION

TURN THE SWITCH OFF THE POWER SUPPLY TO PREVENT FROM UNEXPECTED INJURY. BE SURE TO CONFIRM THE STOP OF ROTATION OF THE MOTOR BEFORE OPERATIONS.

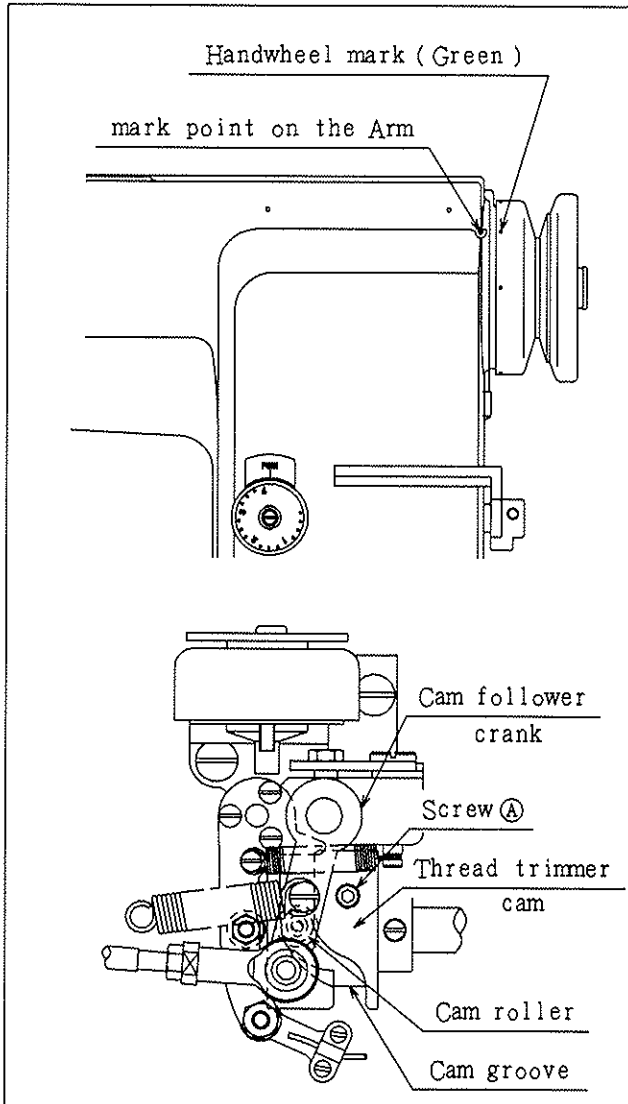

- (1) Turn the handwheel by hand until the needles reach the lowest position.
- (2) Maintaining the needle position, depress the cam follower crank and put the cam roller into the groove of the thread trimmer cam.
- (3) Turning the handwheel by hand, adjust the thread trimmer cam so that the movable knife starts moving when the green mark point on the handwheel comes in line with the mark point on the arm.
To adjust, loosen two thread trimmer cam clamp screws **A**.

25. ADJUSTMENT OF THREAD TENSION REGULATOR

CAUTION TURN THE SWITCH OFF THE POWER SUPPLY TO PREVENT FROM UNEXPECTED INJURY. BE SURE TO CONFIRM THE STOP OF ROTATION OF THE MOTOR BEFORE OPERATIONS.

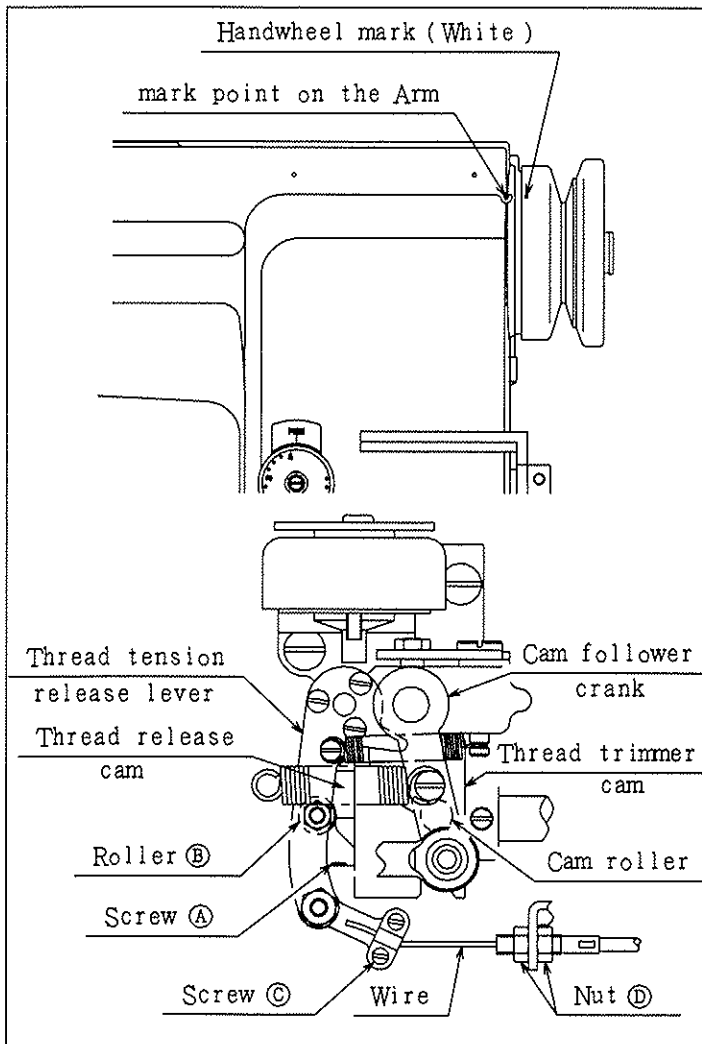

- (1) Turn the handwheel by hand until the needles reach the lowest position.
- (2) Maintaining the needle position, depress the cam follower crank and put the cam roller into the groove of thread trimmer cam.
- (3) Turning the handwheel by hand, adjust the thread tension release cam so that the tension disc close when the white mark point on the handwheel comes in line with the mark point on the arm.
To adjust, loosen two tension release cam clamp screws ①.
- (4) Opening degree of tension disk should be adjusted with the tension release roller ② mounted on the convex portion of thread release cam, as shown in Fig.
To adjust, loosen the screws ③ and draw the wire.
- (5) Make fine adjustment by loosening the nut ④.

26. ADJUSTMENT OF MESHING PRESSURE OF MOVABLE KNIFE AND FIXED KNIFE

CAUTION TURN THE SWITCH OFF THE POWER SUPPLY TO PREVENT FROM UNEXPECTED INJURY. BE SURE TO CONFIRM THE STOP OF ROTATION OF THE MOTOR BEFORE OPERATIONS.

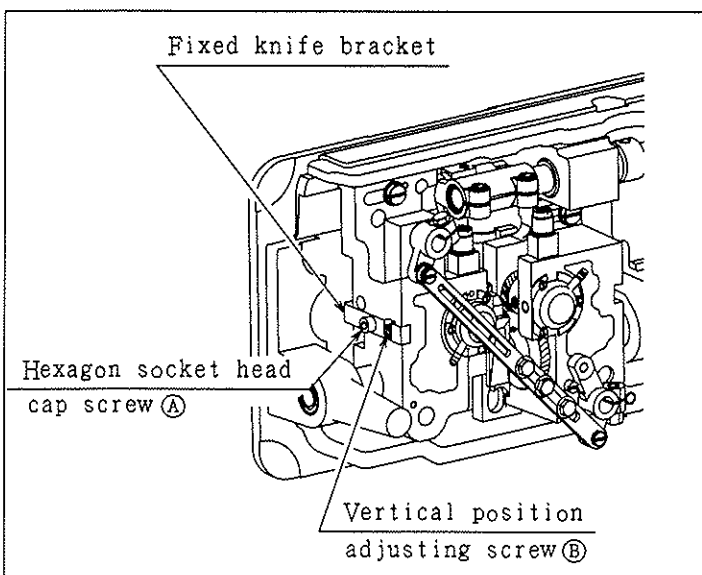

- (1) Loosen the fixed knife bracket clamp hexagon socket head cap screw ①.
- (2) Turn the vertical position adjusting screw ② to adjust meshing pressure and then tighten the hexagon socket head cap screw ①.

Note: Since excess pressure causes large torque to the thread trimming mechanism and trimming failure, adjust it so that thread can be trimmed with minimum pressure.

- (3) Move the movable knife and check that the thread can be sharply trimmed.

27. ADJUSTMENT FOR CHANGE OF NEEDLE GAUGE (FOR CS-4250-BT)



CAUTION

TURN THE SWITCH OFF THE POWER SUPPLY TO PREVENT FROM UNEXPECTED INJURY. BE SURE TO CONFIRM THE STOP OF ROTATION OF THE MOTOR BEFORE OPERATIONS.

- (1) Replace the throat plate, feed dog and needle clamp.
(Since the throat plate and feed dog are special parts designed for thread trimming machine, be sure to use those specified by us.)
- (2) Lean the machine head backward.
- (3) Loosen two connecting link clamp bolts (J).
- (4) Remove the spring (M).
- (5) Loosen the hook bracket clamp screws (A) and (B) and adjust gap between each needle and hook
- (6) When the needles and hooks have been adjusted, install the spring (M).
- (7) Contact the rocking cranks (C) and (D) to the stopper pins (E) and (F) and tighten the connecting link clamp bolt (J).
- (8) Turn the handwheel by hand until the needles reach the lowest position.
- (9) Loosen the nut (G) and (H).
- (10) Depress the cam follower crank (K) and adjust the connecting rod (L) so that the cam roller can smoothly enter the groove of thread trimmer cam. Then tighten the nut (G) and (H).
- (11) Adjustment of the cam groove and the cam roller.
 - (a) Push the cam follower crank (K) so that the cam roller enters into the cam groove.
 - (b) Turn the connecting rod (L) and adjust the clearance between the cam roller and the cam groove surface (N) as small as possible, and tighten the nuts (G) and (H).
 - (c) Push the cam follower crank (K) again and check that the cam roller enters into the thread trimmer cam groove smoothly.

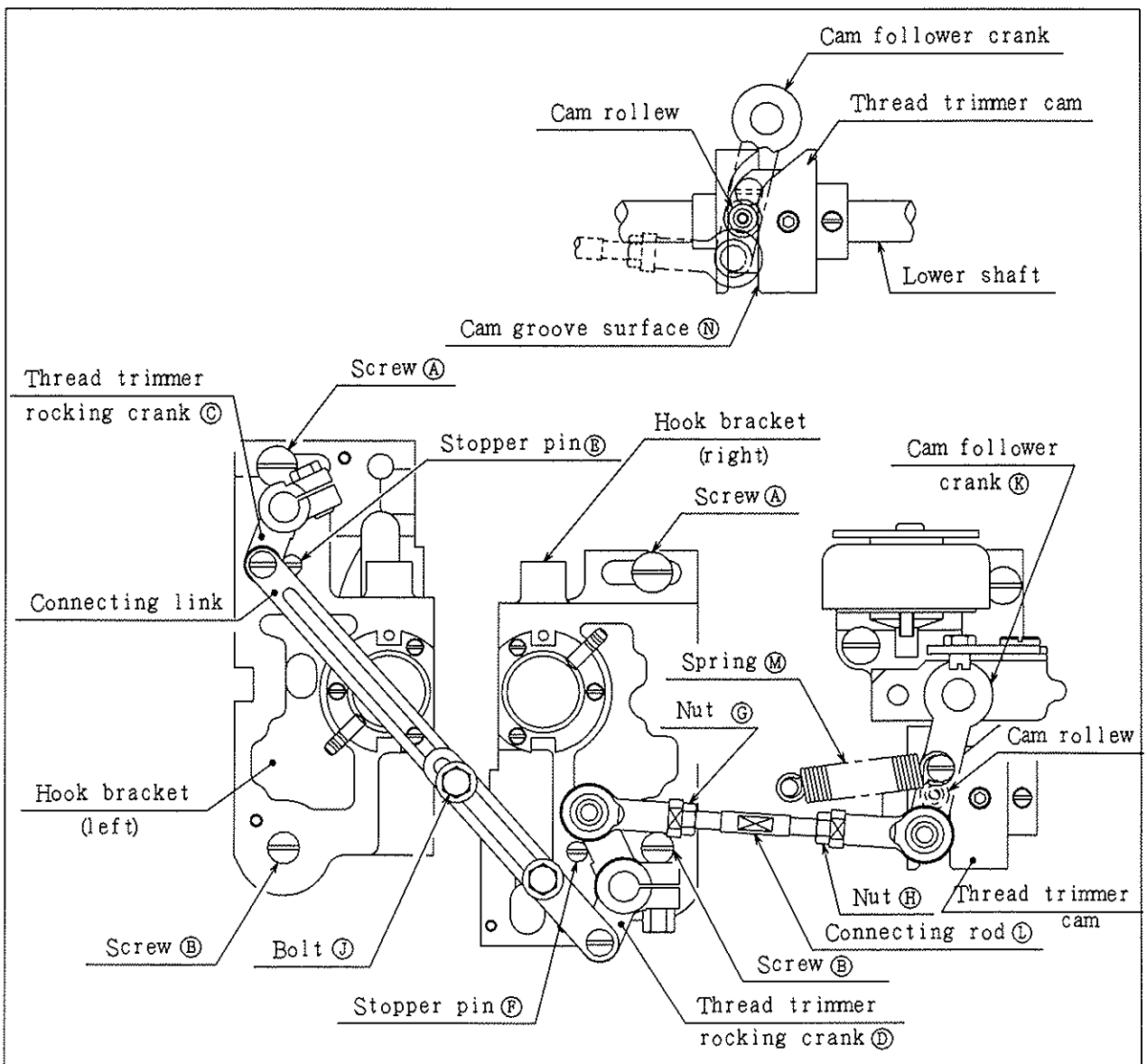

28. TROUBLE AND CORRECTIVE MEASURES

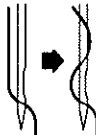
Trouble	Causes	Corrective measures
1. Thread breakage (Thread frays or wears out.) Needle thread remains 2 to 3 cm on the wrong side of the cloth)	<ul style="list-style-type: none"> ① The thread path, needle point, hook point or bobbin case positioning finger has scratches. ② The needle thread tension is too high. ③ The needle hits the hook point. ④ Lubrication to hook is inadequate. ⑤ The needle thread tension is too low. ⑥ The thread take-up spring has an excessively high tension while it has an excessively small stroke. ⑦ The timing between the needle and hook is too early or late. 	<ul style="list-style-type: none"> ○ Remove the scratches on the hook point using a fine sand paper, Buff the bobbin case positioning finger. ○ Properly adjust the needle thread tension. ○ See '15 NEEDLE TO HOOK RELATIONSHIP'. ○ Properly adjust the lubrication. See '5 REFUELING ADJUSTMENT OF THE HOOK'. ○ Properly adjust the needle thread tension. ○ Decrease the tension, and increase the stroke. ○ See '15 NEEDLE TO HOOK RELATIONSHIP'.
2. Stitch skipping	<ul style="list-style-type: none"> ① The clearance between the needle hook point and the is too large. ② The timing between the needle and hook is too early or late. ③ The presser foot pressure is too low. ④ The clearance between the top edge of the needle eyelet and the hook point is not correct. ⑤ The size of the needle is wrong. ⑥ A synthetic fiber thread or thin thread is used. 	<ul style="list-style-type: none"> ○ See '15 NEEDLE TO HOOK RELATIONSHIP'. ○ See '15 NEEDLE TO HOOK RELATIONSHIP'. ○ Increase the presser foot pressure ○ See '15 NEEDLE TO HOOK RELATIONSHIP'. ○ Replace the needle by one which one grade thicker. ○ Wind the thread round the needle as illustrated. 
3. Loose stitches	<ul style="list-style-type: none"> ① The thread has not been the passed the through notch of the bobbin case tension spring. ② The thread path is poorly finished ③ The bobbin does not rotate smoothly. ④ The bobbin thread tension is too low. ⑤ The bobbin thread has been wound too tight. 	<ul style="list-style-type: none"> ○ Properly thread the bobbin case. ○ Grind it using a fine sand paper of a buff. ○ Replace the bobbin or hook. ○ Properly adjust the tension. ○ Decrease the bobbin thread winding tension.
4. The thread slips off the needle up on being trimmed	<ul style="list-style-type: none"> ① The tension of the auxiliary thread tension controller is too high. ② The thread trimming timing is too early. ③ The returning force of the thread take-up spring is too high. 	<ul style="list-style-type: none"> ○ Decrease the tension. ○ See '25 ADJUSTMENT OF THREAD TENSION REGULATOR'. ○ See '24 ADJUSTMENT OF THREAD TRIMMER CAM'. ○ Adjust the high of the thread take-up spring.
5. The needle thread cannot be trimmed, while the bobbin thread can be trimmed	<ul style="list-style-type: none"> ① The last stitch has been skipped. (The clearance between the needle and the hook is too large.) 	<ul style="list-style-type: none"> ○ See '15 NEEDLE TO HOOK RELATIONSHIP'.
6. Both needle and bobbin threads cannot be trimmed	<ul style="list-style-type: none"> ① The thread trimming timing is wrong. ② The knife has been damaged. ③ The knife pressure is inadequate. ④ The home position of the movable knife is inaccurate. ⑤ The movable knife fails to work. ⑥ The thread trimming solenoid fails to work. 	<ul style="list-style-type: none"> ○ See '24 ADJUSTMENT OF THREAD TRIMMER CAM'. ○ Replace the knife. ○ Increase the knife pressure. ○ See '24 ADJUSTMENT OF THREAD TRIMMER CAM'. ○ Check it by actuating it by hand. ○ Check the motor solenoid for proper operation.
7. Thread cannot be trimmed sharply	<ul style="list-style-type: none"> ① The thread trimming timing is wrong. ② The knife pressure is inadequate. ③ The knife blade is blunt. 	<ul style="list-style-type: none"> ○ See '24 ADJUSTMENT OF THREAD TRIMMER CAM'. ○ Increase the knife pressure. ○ Replace the knife.

GOLDEN WHEEL CHEE SIANG INDUSTRIAL CO., LTD
啓翔股份有限公司 No. 32, Wu Chuan 7th Road, Wu Ku Industrial Area,
Wu Ku Hsiang 2424B, Taipei Hsien, Taiwan
Tel:886-2-22999518 Fax:886-2-22999519

* Appear and specification listed in this instruction manual are subjected to change without notice.

03.09 printed in Taiwan